

UNIVERSITÀ DI BOLOGNA

Dipartimento di Ingegneria Elettrica



A Distributed Measurement System for Correlating Faults to Lightning in Distribution Networks

M. Paolone¹, K. Yamabuki¹, A. Borghetti¹, F. Napolitano¹, C.A. Nucci¹, M. Bernardi²

1. University of Bologna, viale del Risorgimento 2, 40136 Bologna, Italy

2. CESI, via Rubattino, 54, 20134 Milano, Italy

Introduction

Sag occurrence (in percent) versus month of the year. Summer is clearly characterized by a larger number of lighting.

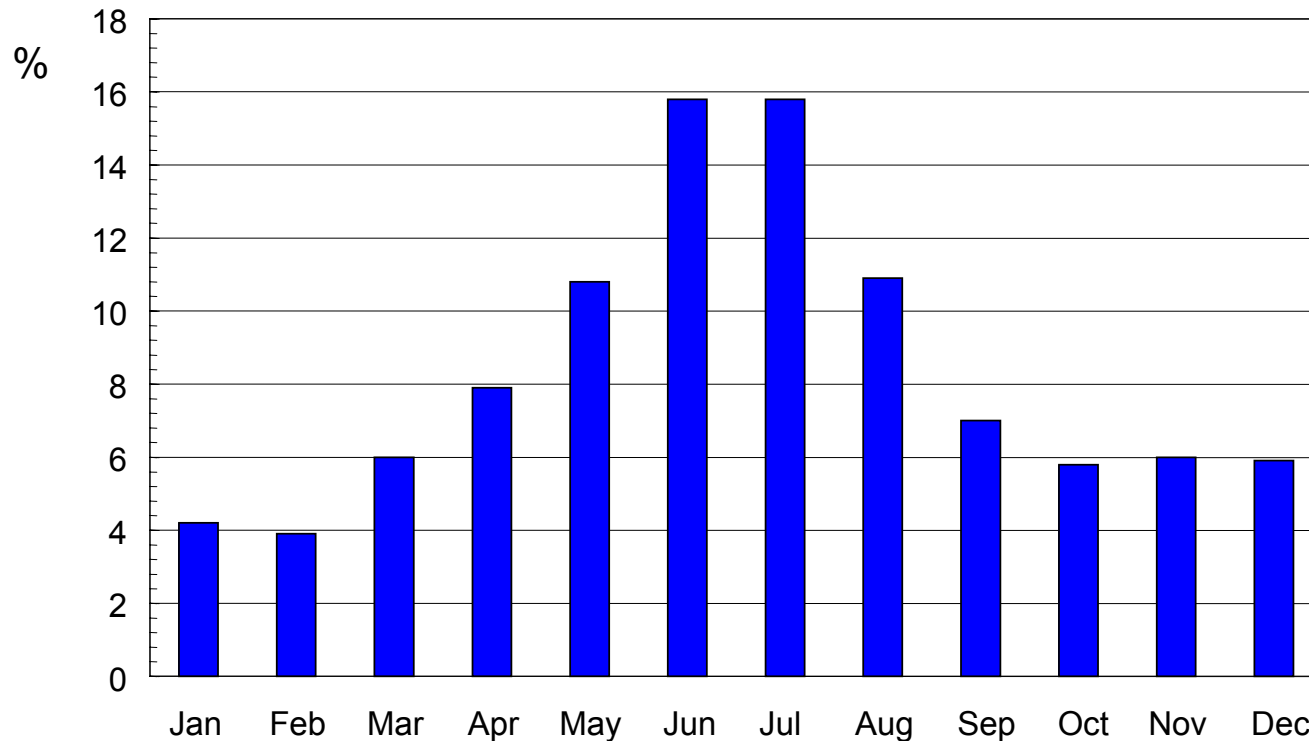

Adapted from: [D.S. Dorr, 'Point of utilization power quality study results', IEEE Trans on Ind. Appl., vol.31, n°4, July. 1995]

Introduction

Cont.

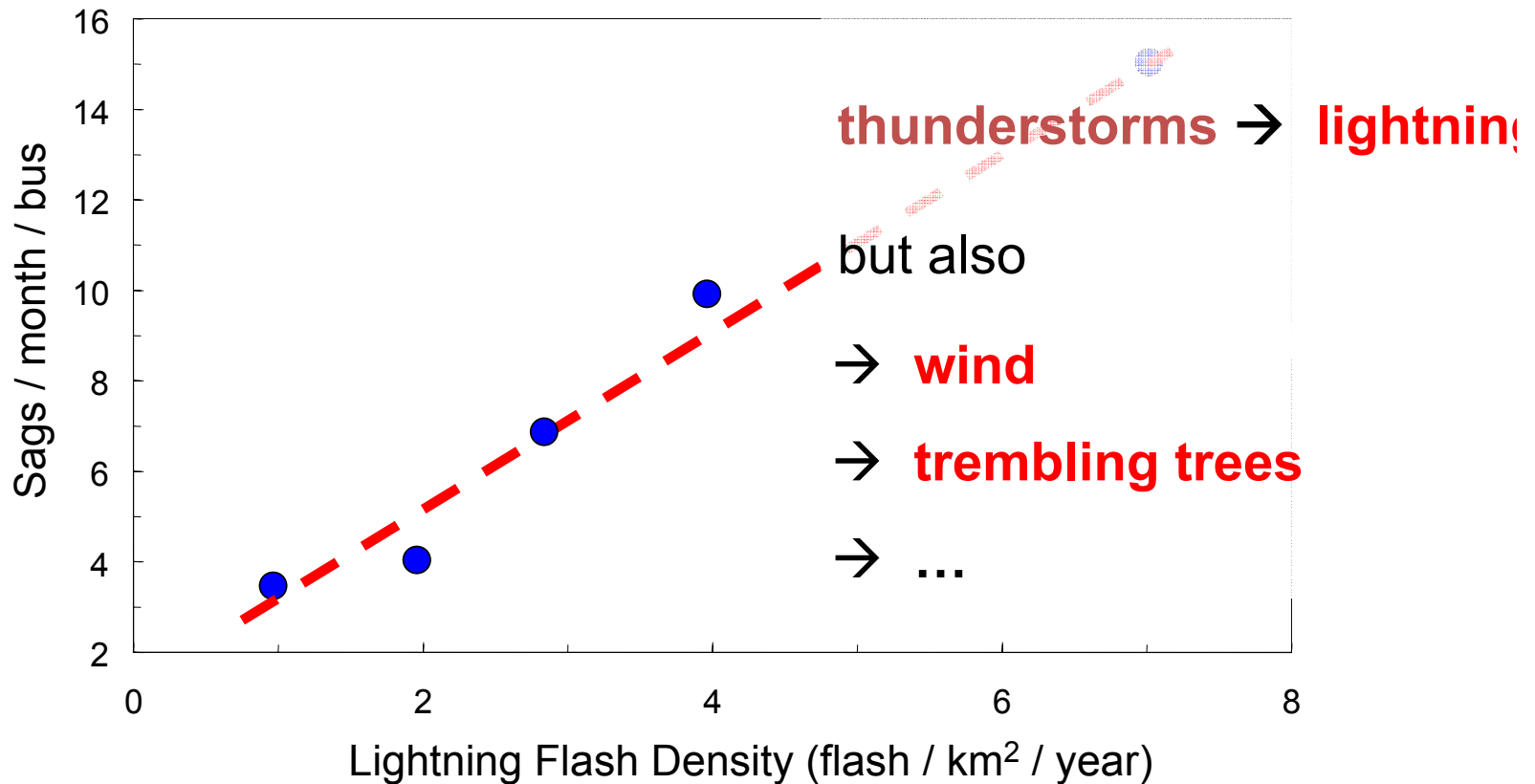

Adapted from E.W. Gunther, H. Metha, 'A survey of distribution system power quality', IEEE Trans on PWD, vol.10, n°1, Jan. 1995]

Correlation procedures

LLSs are useful tools to correlate lightning events to protection relays maneuvers.

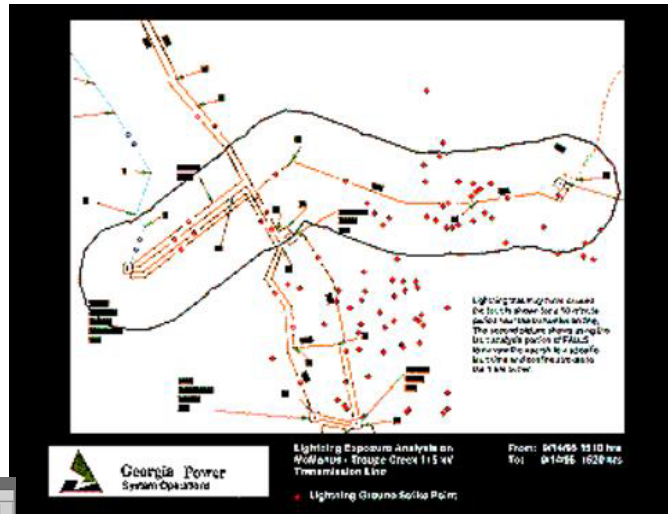

CESI - ENEL

M. Bernardi, C. Giorgi, V. Biscaglia, "Medium voltage line faults correlation with lightning events recorded with the Italian LLP system CESI-SIRF", Proc. 24th ICLP, Birmingham-UK, 1998

- monitoring system of relays operations
- SIRF (Italian LLS)

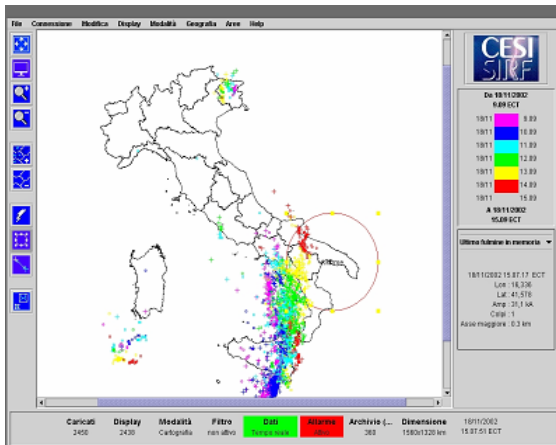

Correlation basically established by means of a **time-window** and **spatial distance criteria**

Correlation procedures

Cont.

Correlation algorithms presented in the literature

→ Typically apply procedures based on ***time-distance criteria*** that assume a lightning event to be the source of a fault if the following conditions are satisfied:

- 1) the ***detected lightning stroke*** and ***relay tripping*** are recorded within a time window of ***few seconds***;
- 2) the ***distance between the estimated stroke location and the closest line is lower than a chosen distance*** (e.g. 1 kilometer), or the ***stroke location error ellipse intersects a corridor limit*** that surrounds the overhead lines.

Correlation procedures

Cont

- complexity of the problem;
- real configuration of distribution network systems must be taken into account.

→ Thorough analysis is needed

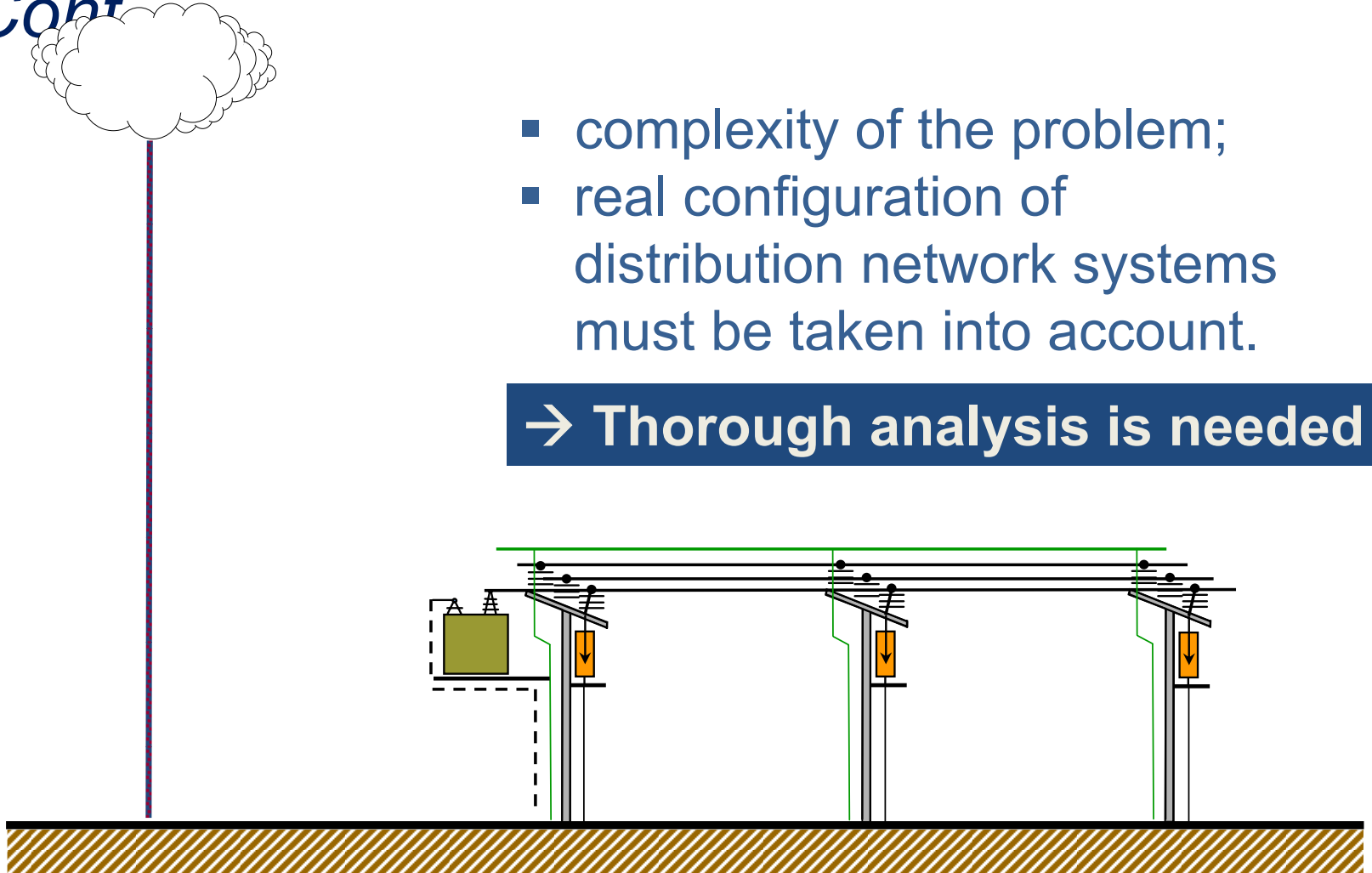

Correlation procedures

Cont.

Recent ***advanced correlation procedures*** are based on the ***integrated use*** of:

- data obtained from ***LLSs*** (already discussed);
- data provided from ***monitoring system of relay operation*** (already discussed);
- ***numerical simulation*** of distribution network response to direct and indirect lightning events taking into account also the ***uncertainty levels associated with the stroke location and peak current estimates*** provided by lightning location systems.

Correlation procedures

Cont.

In particular, the correlation procedure is structured as follows:

- 1.** a set of ***potentially correlated lightning strokes*** are selected by means of a time correlation criterion: ± 1 s (UTC-GPS time synchronization) from the ***fault event occurrence***;

Correlation procedures

Cont

2. for each stroke candidate, a **set of random stroke locations is generated**, by using the bi-variate normal distribution “centered” on the estimated location, with a 50% probability to be inside the **error ellipse** provided by the LLS ;

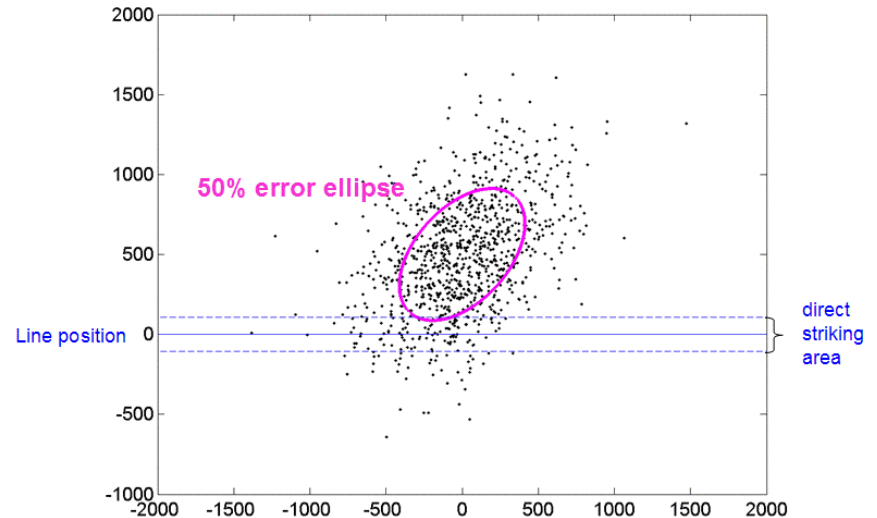
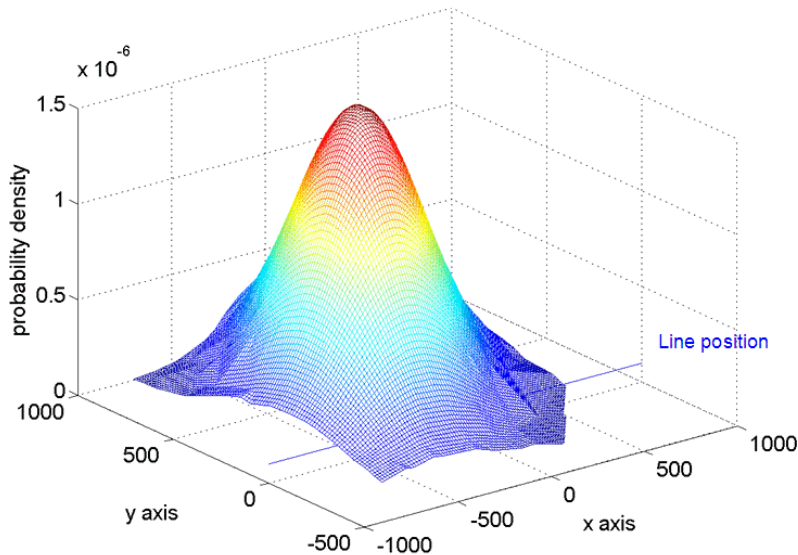

Correlation procedures

Cont

3. a set of **current values** is also generated from the available distribution of **peak current estimation errors**;
4. in order to **distinguish between direct and indirect strokes**, a suitable model of the **lightning incidence** to the distribution lines is applied to each event (e.g. [31]);
5. for the case of both direct and indirect events, the **lightning overvoltages** along the lines are **calculated** and compared with the overhead line insulation withstanding characteristics, i.e., the **CFO** value, which makes it possible to estimate the probability that the detected lightning flash is a cause of fault events

Correlation procedures

Cont

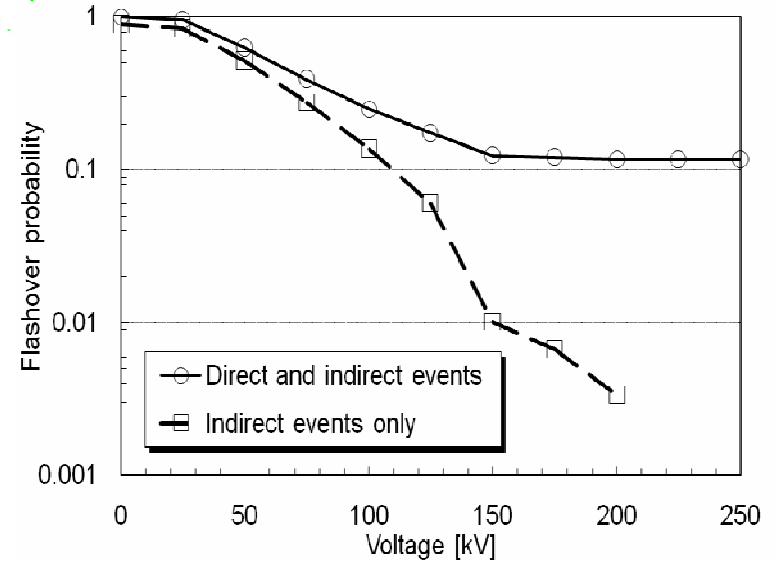
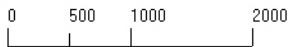
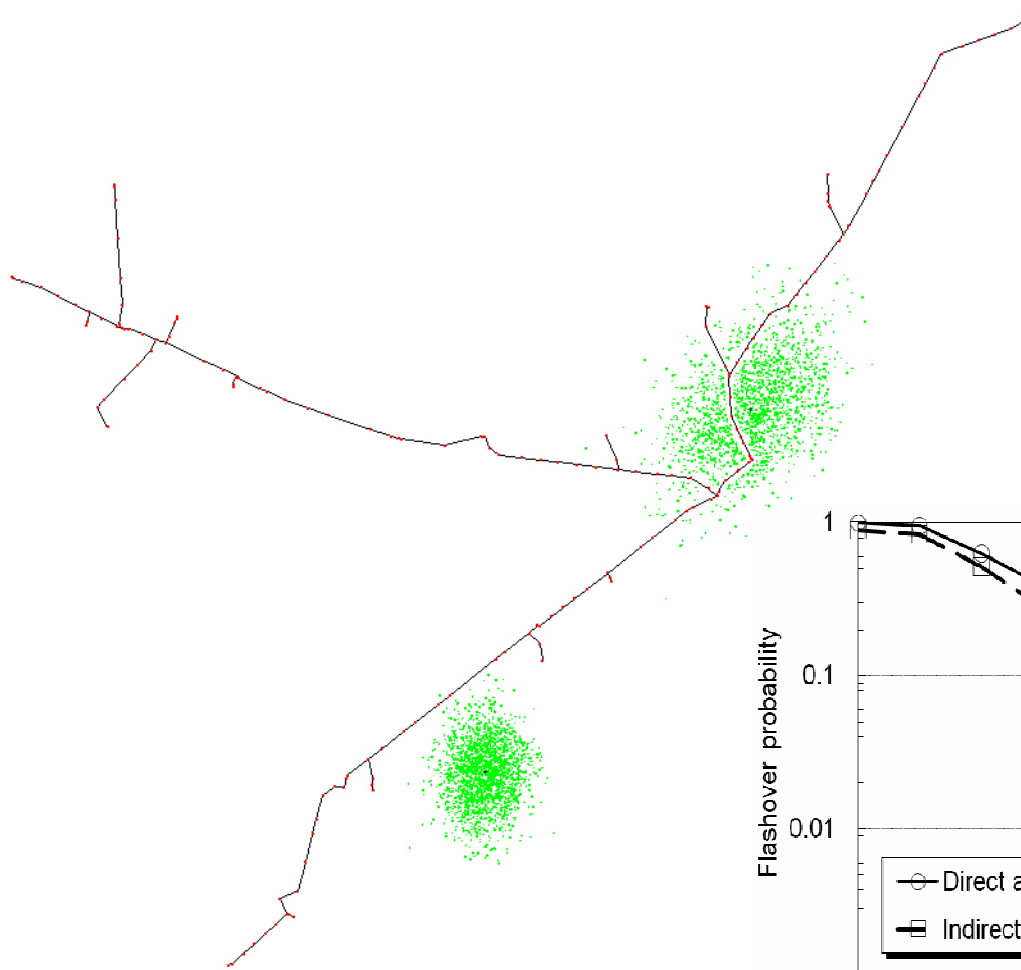

Distributed monitored system

In order to *validate and support* such a correlation procedure, a *distributed monitoring system (DMS)* for detecting lightning-originated transients has been developed.

The proposed DMS preserves the architecture of typical DMSs for power quality monitoring: the units are connected at buses of the monitored network and linked to a central server by means of *local or wide area communication networks*. *Each DMS unit acquires measurements of phase-to-ground voltages*, and performs *specific signal processing functions*.

Distributed monitored system

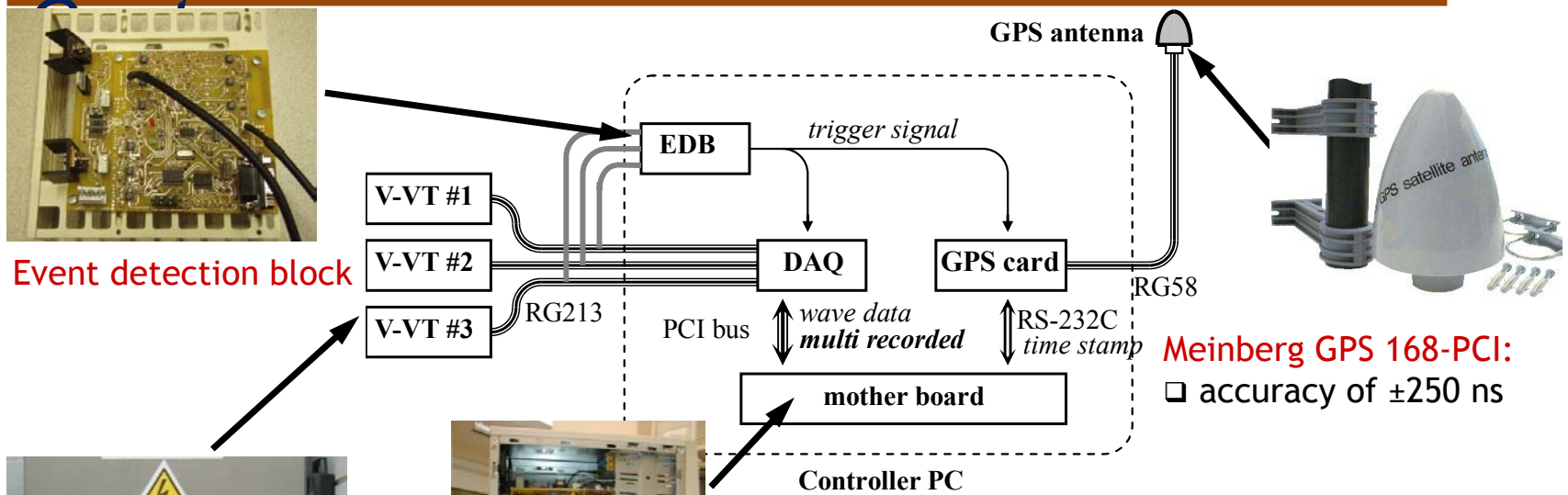

Event detection block

Meinberg GPS 168-PCI:
 □ accuracy of ± 250 ns



Controller PC

NI PCI 5112 digitizer:

- 8-bit
- sampling frequency of 100 MS/s
- accuracy of $\pm 0.5\%$
- storage capability of 16 MPts

Pearson capacitive voltage divider VD-305A:

- 300 kV peak
- nominal ratio 10 kV / 1 V
- bandwidth 30 Hz \div 4 MHz (-3 dB)
- rising time 100 ns
- accuracy $\pm 1\%$

Distributed monitored system

Cont.
The capacitive voltage divider
Pearson VD-305A has been suitably
modified in order to increase its **CFO**
up to 300 kV

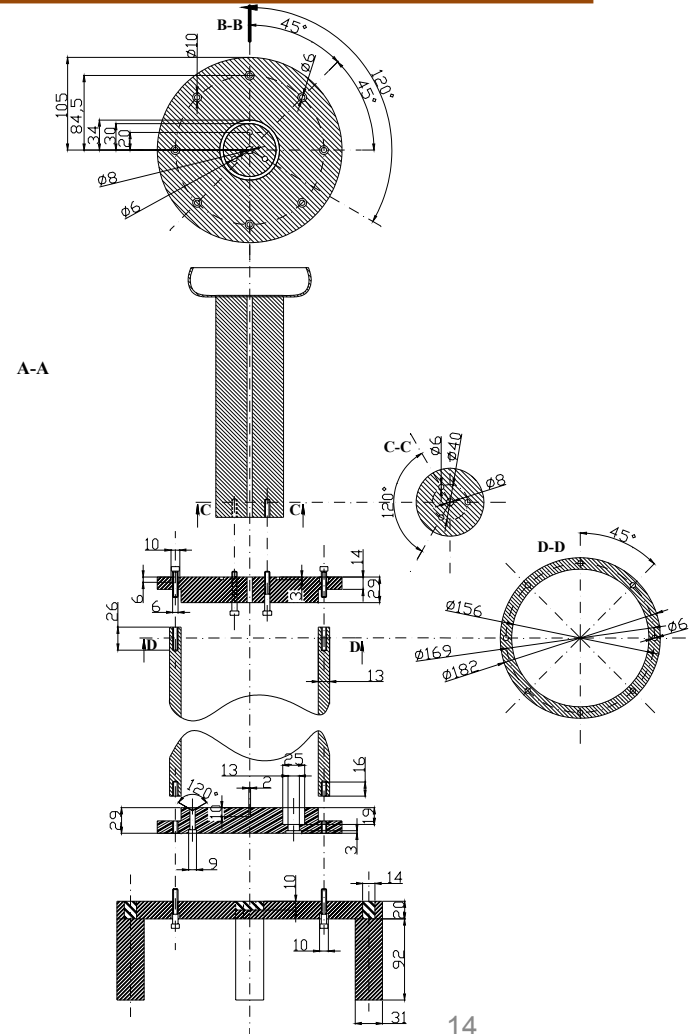
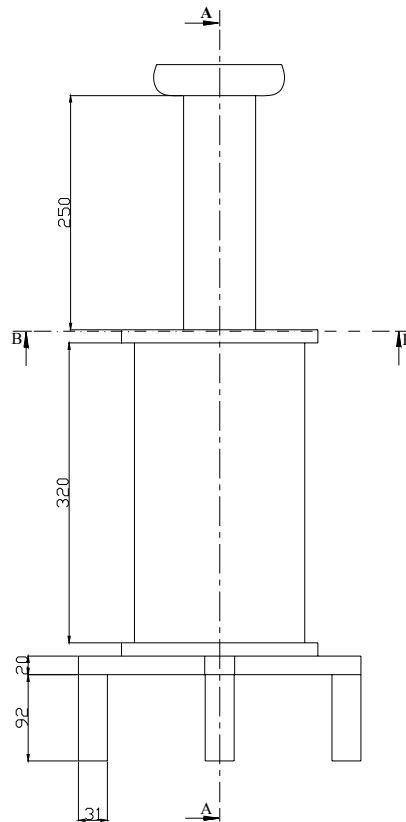

Distributed monitored system

Cont

Experimentally determined V-VT transfer function: *dividing ratio*

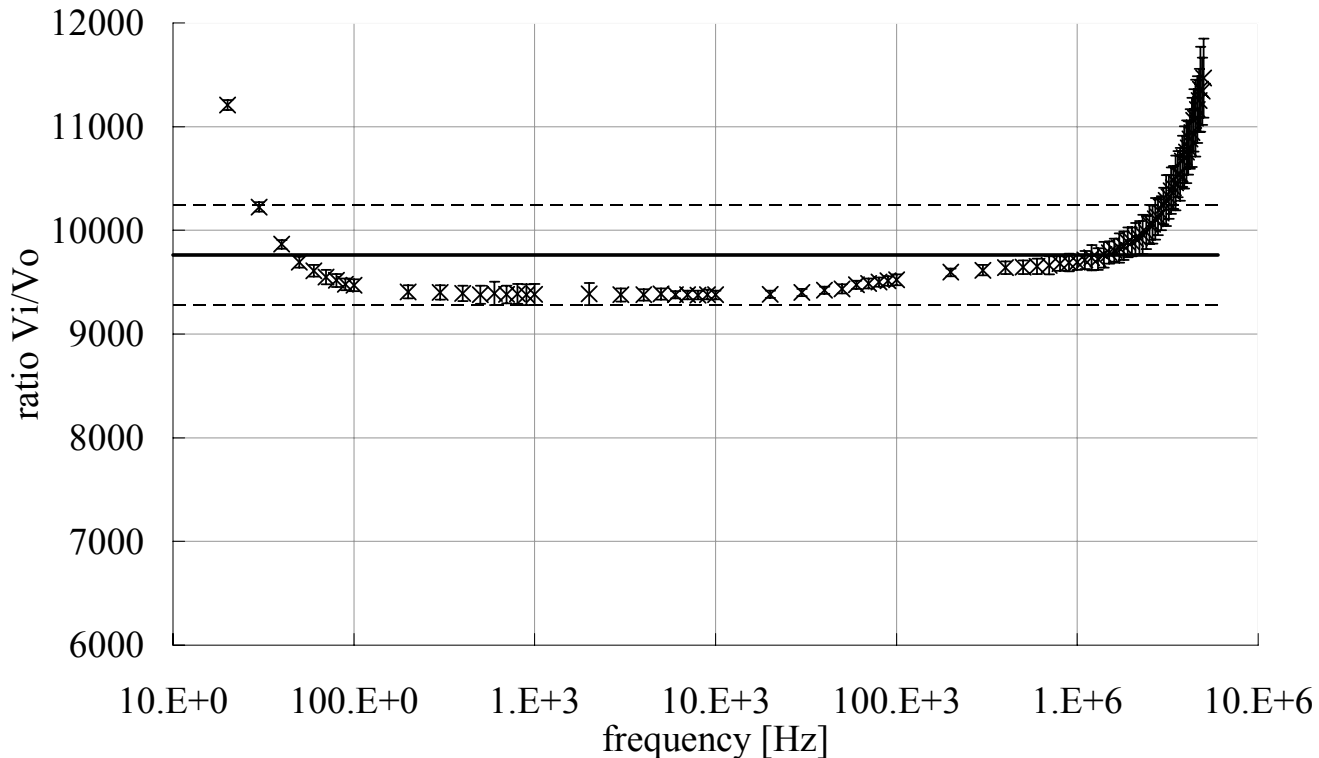

NOTE: For each analyzed frequency, 50 measurements have been performed: the cross marks of figure represent the mean values, whilst the vertical bars show the *95% confidence interval*.

Distributed monitored system

Cont

Experimentally determined V-VT transfer function: *phase shift*

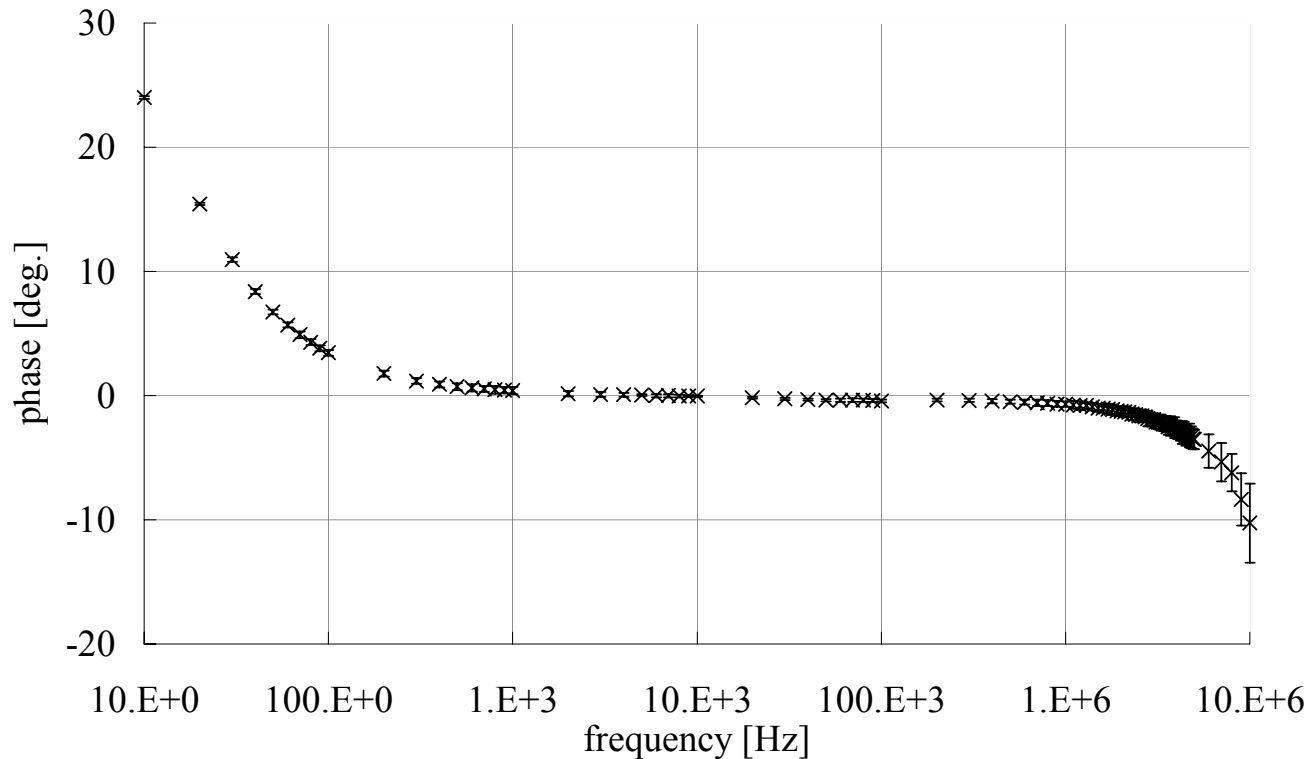

NOTE: For each analyzed frequency, 50 measurements have been performed: the cross marks of figure represent the mean values, whilst the vertical bars show the *95% confidence interval*.

Distributed monitored system

Event detection block – EDB

→ Detection of transients superimposed to the 50Hz sinusoidal voltage

- receives the input of the 3 V-VTs;
- provides, as output, a TTL pulse (negative logic) in presence of a transient superimposed to the industrial frequency waveform;
- **operation**: the EDB performs an **analog subtraction** between the **negative-offset input waveform** and the **low-pass-filtered input waveform**; the presence of a **transient**, characterized by frequency contents greater than the LPF low-pass frequency value, **produces a difference between the input waveforms** of the comparator able to change its status.

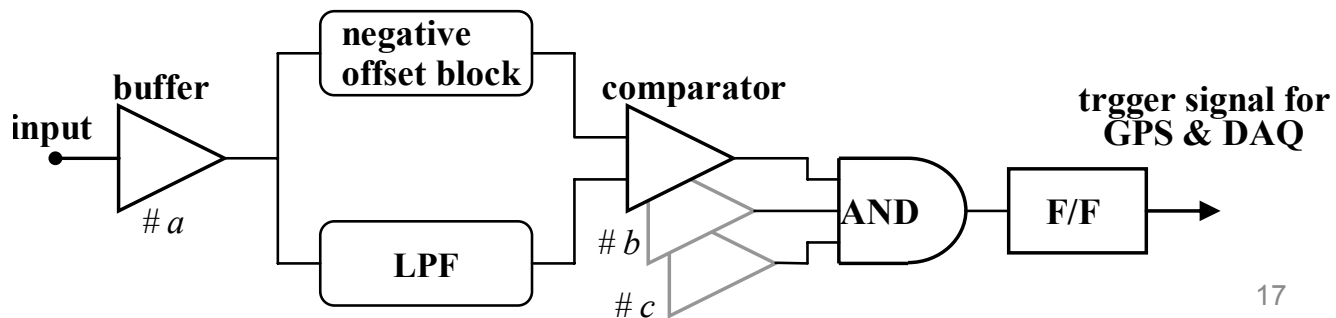

Distributed monitored system

Event detection block – EDB

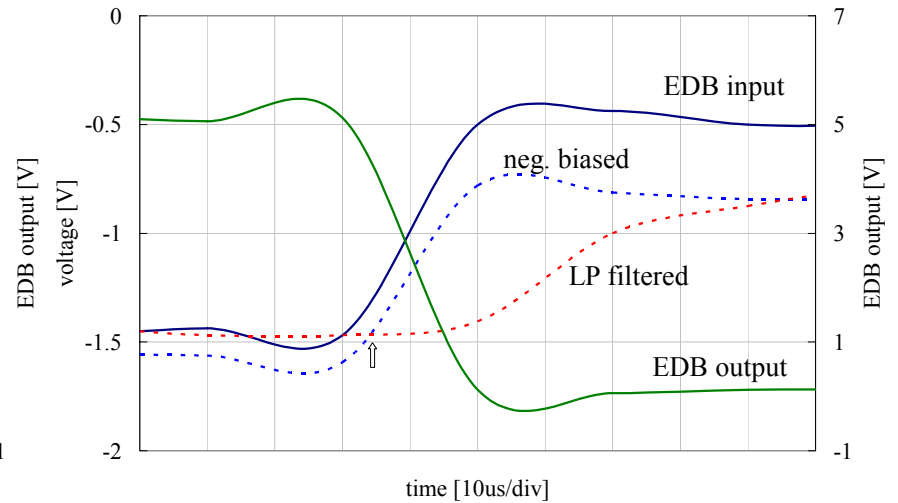
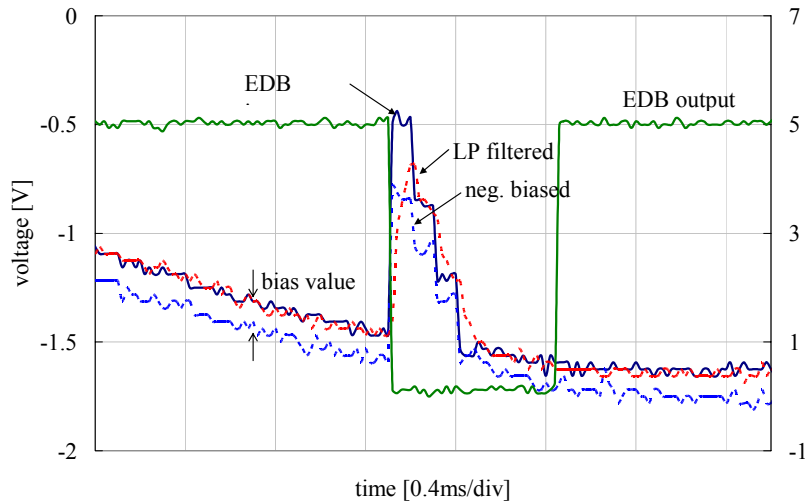

Distributed monitored system

Event detection block – EDB

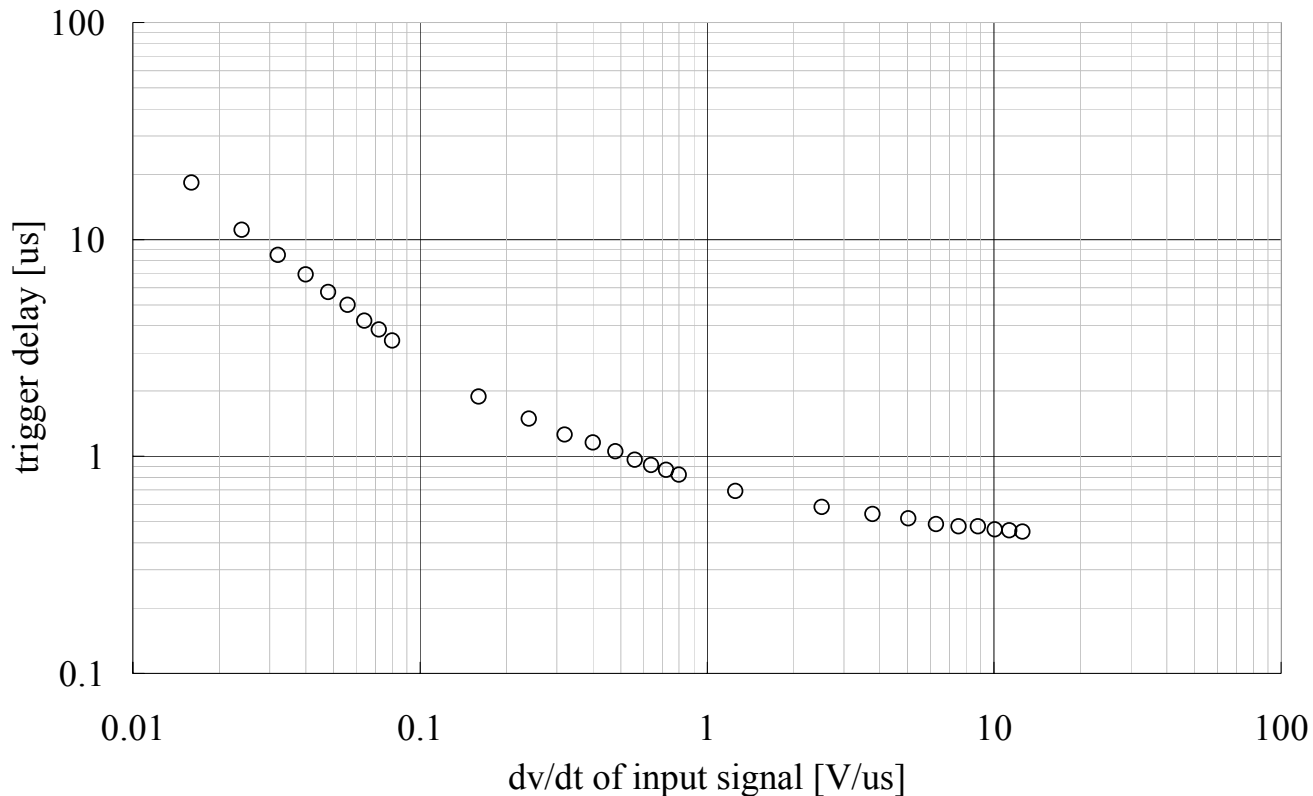

Assuming a voltage amplitude range from 10 to 100kV and a rise time range from 0.1 to 10 μs , we obtain a range of dV/dt from 0.1 to 100 $\text{V}/\mu\text{s}$. Therefore, considering the typical V-VT ratio (10.000), the **trigger delays become up to**

Distributed monitored system

Cont.

DMS Settings	variable
Time window for a stroke (including pre-trigger 20%)	1.5ms (0.3ms)
Sampling frequency	100 MSa/s
Number of sample for a flash	15000pts
Waiting time for a flash [= a group of sequential strokes]	5s
Maximum number of subsequent transients grouped within the same event	20
Vertical range of DAQ (corresponding voltage considering the V-VT)	$\pm 15V$ ($\pm 150kV$)

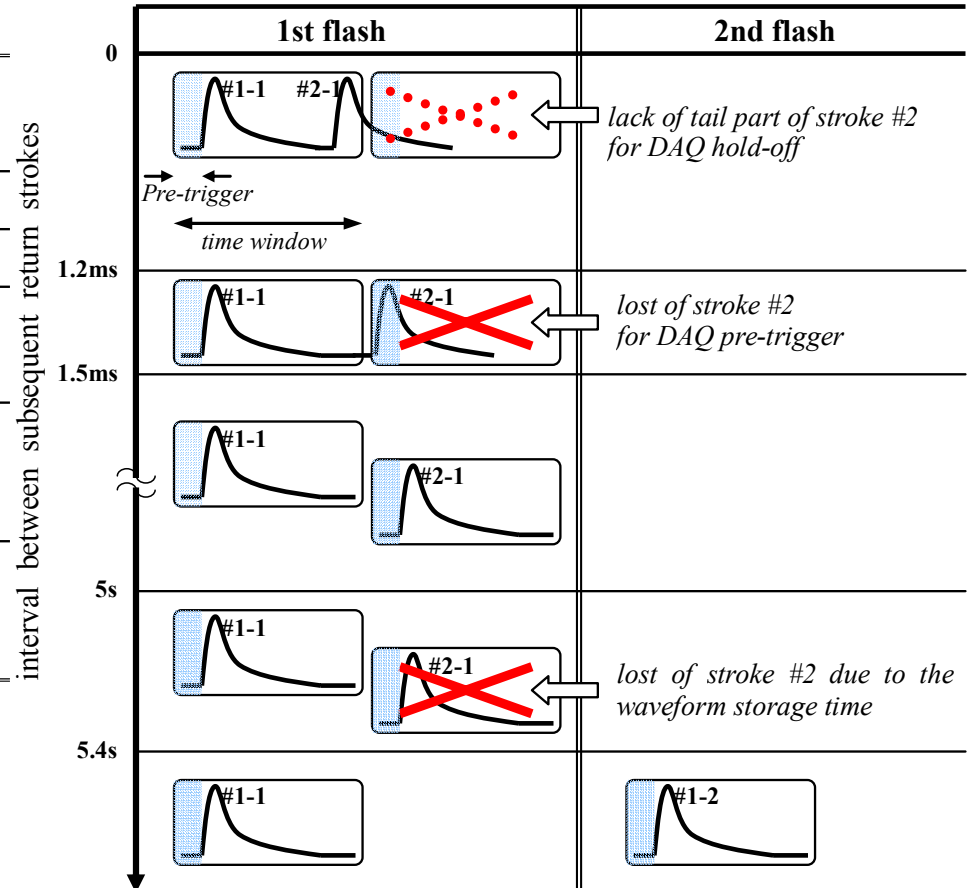

Distributed monitored system

DMS installation

The developed DMS has been installed at the end of February in a distribution network located in the northern part of Italy. Figure shows the network topology, the position of the DMS units and the lightning stroke locations (599 strokes of 247 flashes) recorded by the Italian LLS CESI-SIRF during August 2006.

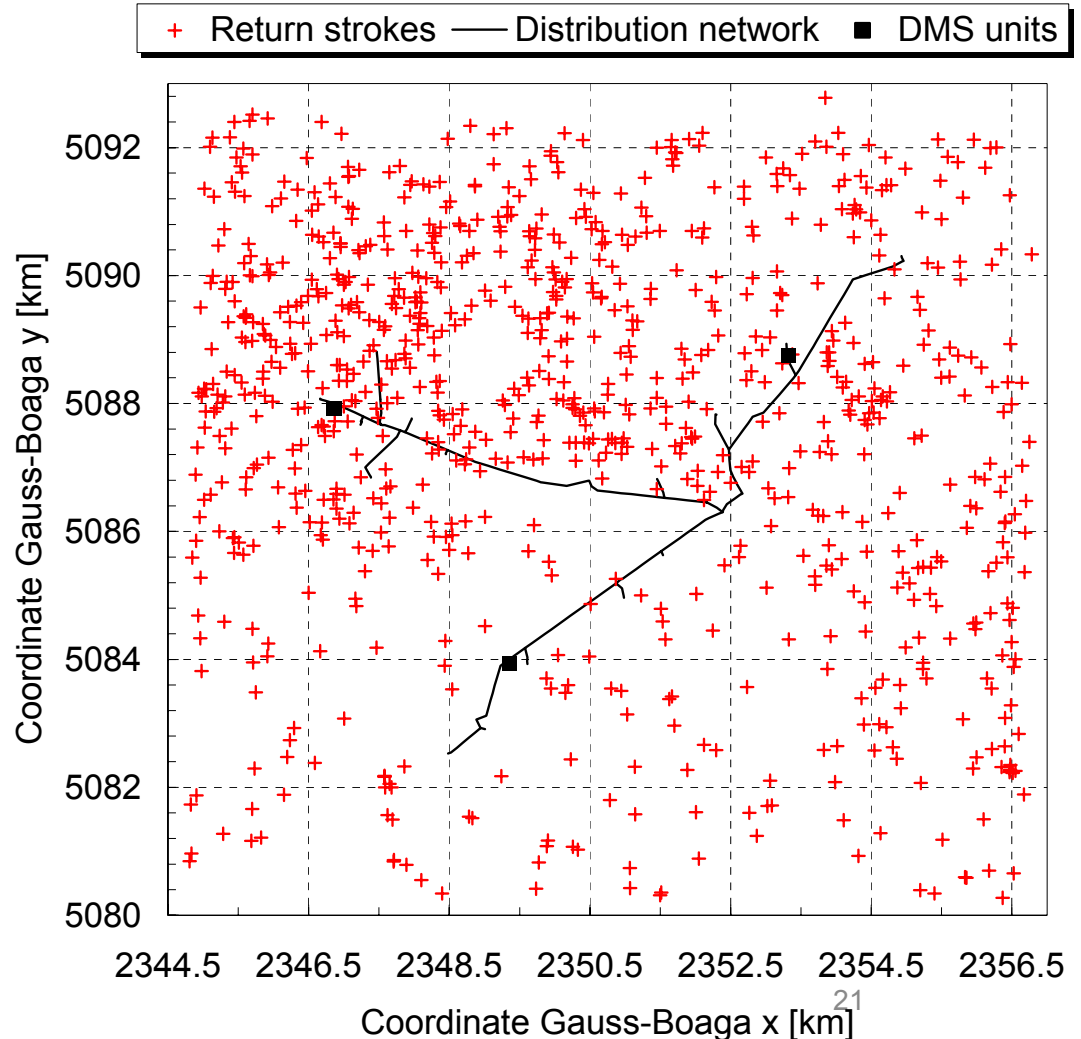

Distributed monitored system

Cont



Conclusions

The combined integration of (i) LLSs, (ii) monitoring system of relay operations, (iii) accurate models/computer codes for the calculation of overvoltages due to direct/indirect lightning and (iv) the proposed DMS, represent a powerful tool for power quality monitoring in distribution networks.

- Their coordinated use can provide an improved estimation of the correlation between lightning events and voltage sags.
- The contribute has described, the structure and peculiar characteristics of a DMS for the measurement of lightning-originated transients. The performances of the developed DMS have been determined experimentally and have been shown to be adequate for