

# Introduction to the physics of sprites, elves and intense lightning discharges

**Michael J. Rycroft**

CAESAR Consultancy, 35 Millington Road, Cambridge CB3 9HW, and  
Centre for Space, Atmospheric and Oceanic Science,  
University of Bath, Bath BA2 7AY, U.K.

Chapter 1, in

“Sprites, Elves, and Intense Lightning Discharges”

Proceeding of NATO Advanced Study Institute, July 2004, Corsica

Edited by M. Füllekrug, M., E.A. Mareev, M.J. Rycroft

Springer, 398 pages, 2006

ISBN : 978-1-4020-4628-6 (soft cover)

ISBN : 978-1-4020-4627-8 (hardback)

## ATMOSPHERIC IONS

**For the atmosphere of Earth, or any other planet, the most significant variation is due to GRAVITY.**

**For Earth, density of neutral gas decreases exponentially, with scale height,  $H \sim 7$  km.**

**Thus, for each 15 km of altitude, density decreases by an order of magnitude.**

**Atmosphere is slightly electrified (weakly conducting) due to IONIZATION by COSMIC RAYS.**

**Maximum production at  $\sim 15$  km to 20 km altitude**

**(Aplin and McPheat, 2005, Usoskin et al., 2005, Tinsley and Zhou, 2006).**

**Also, at sub-auroral latitudes, due to relativistic electron precipitation (REP,  $\sim 1$  MeV) events.**

**Also, within polar cap, due to occasional solar energetic proton (SEP,  $\sim 100$  MeV) events.**

**At the Earth's surface, and up to a few km altitude, over land, due to RADON (a radioactive element) emanating from Earth.**

**Produces  $\sim$  few (up to 10)  $\times 10^6$  ion pairs /m<sup>3</sup>/s.**

## ATMOSPHERIC IONS

Ions collide with, and attach to, molecules, forming small cluster ions, e.g.,  $H^+(H_2O)_n$ , so humidity is important; also attach to pollutants.

Small cluster ions attach to aerosols, forming large ions.

Spectrum of sizes – growth to cloud condensation nuclei (CCN) ?

(Yu and Turco, 2001, Harrison and Carslaw, 2003).

Ion mobility  $\mu = \text{velocity} / \text{electric field}$  m/s/V/m (or  $m^2/Vs$ ).

Largest for smaller ions, in cleanest air, decreasing as mass increases.

Spectrum of mobilities (Aplin, 2005).

**ELECTRICAL CONDUCTIVITY** is due mainly to small ions.

$$\sigma = q_+ N_+ \mu_+ + q_- N_- \mu_- \approx 2 e N \mu$$

where  $e (=q)$  is the magnitude of charge on electron, and

$N$  is ion number density,  $\sim 10^9 / m^3$ , at ground level,

maximum,  $\sim 6 \times 10^9 / m^3$ , at 15 km altitude.

## ELECTRICAL CONDUCTIVITY

$\sigma$  above Earth's surface  $\sim 10^{-14}$  S/m

at 30 km altitude  $\sim 10^{-11}$  S/m

at 55 km altitude  $\sim 10^{-10}$  S/m

at 80 km altitude  $\sim 10^{-7}$  S/m (night-time)

Conduction current density  $\underline{J} = \sigma \underline{E}$  (Ohm's law).

$\sigma$ , scalar in atmosphere, tensor in ionosphere above 80 km altitude.

Gauss's law  $\text{div } \underline{E} = \rho / \epsilon_0$ ; in one dimension  $dE(z)/dz = \rho(z) / \epsilon_0$ .

Charge layers exist wherever  $E(z)$  changes markedly with  $z$ .

Columnar resistance  $R_c = \int_0^{\text{ionosphere}} \frac{dz}{\sigma(z)}$ , for a column of unit area.

Generally, > 95% is below 10 km (Harrison and Bennett, 2007).

## GLOBAL ATMOSPHERIC ELECTRIC CIRCUIT

**D.C. Sources: thunderstorms, electrified shower clouds**  
**convection      stratospheric aerosols from volcanoes**

**TYPICAL VALUES Fair weather region**

**Potential gradient = - E     $\approx 130$  V/m       $J_z \sim 2$  pA/m<sup>2</sup> (reduced in polluted air,  
Harrison and Bennett, 2007)**

**Ionospheric potential       $\sim 250$  kV      Total current  $\sim 1$  kA.**

**For 1 m<sup>2</sup> column from ionosphere down to Earth's surface,**

$$J_z = 2\text{pA/m}^2 = \frac{\text{ionospheric potential, V}}{R_c} = \frac{250\text{kV}}{125\text{P}\Omega\text{m}^2} \quad .$$

**A.C. Source: lightning discharges      intracloud (IC)**  
**cloud-to-ground (CG)**  
**both – and + CG.**

**Experiments: on surface, from aircraft, radiosondes,  
large balloons, rockets, satellites.**

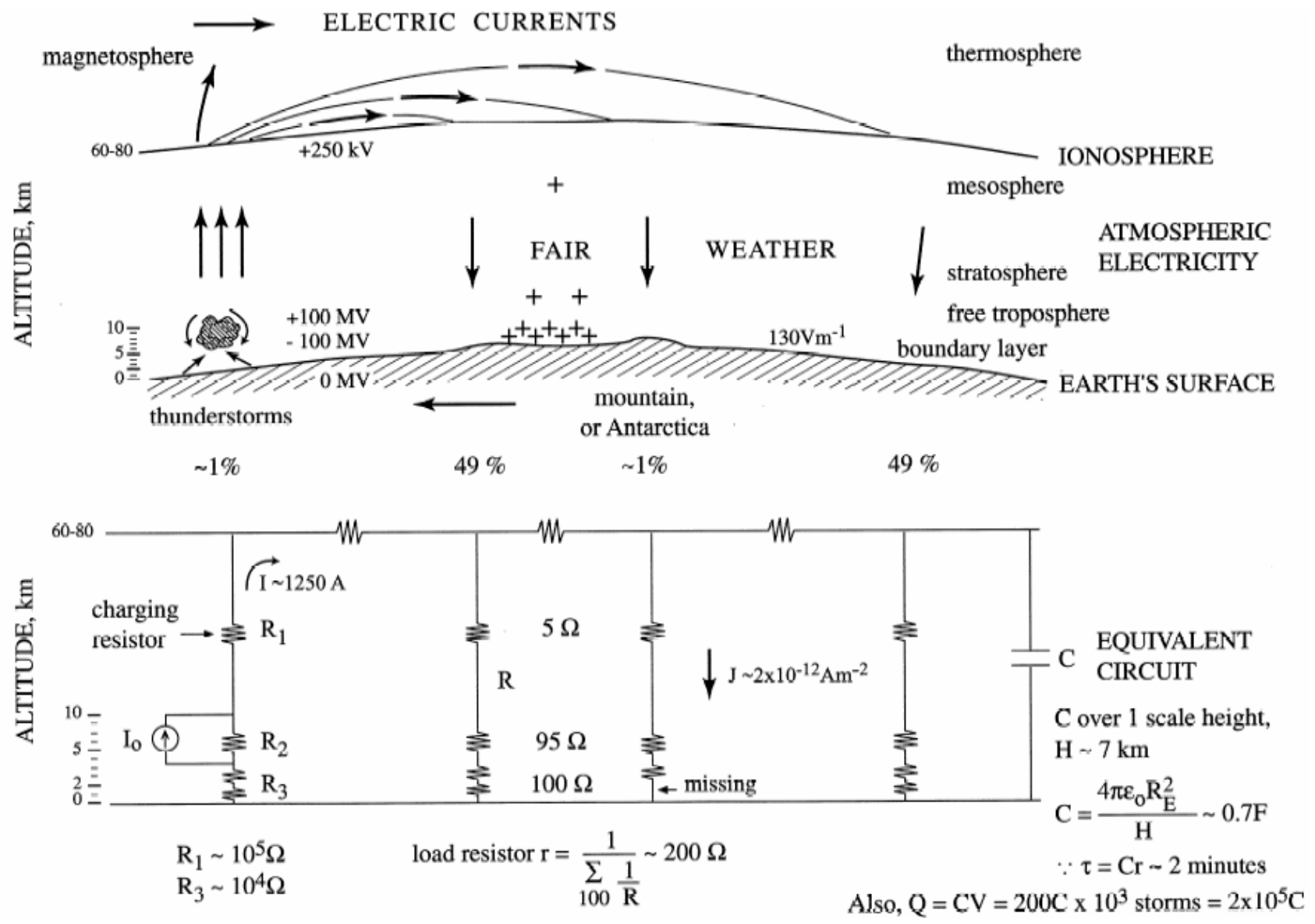

Rycroft et al., JASTP, 2000, Fig. 5

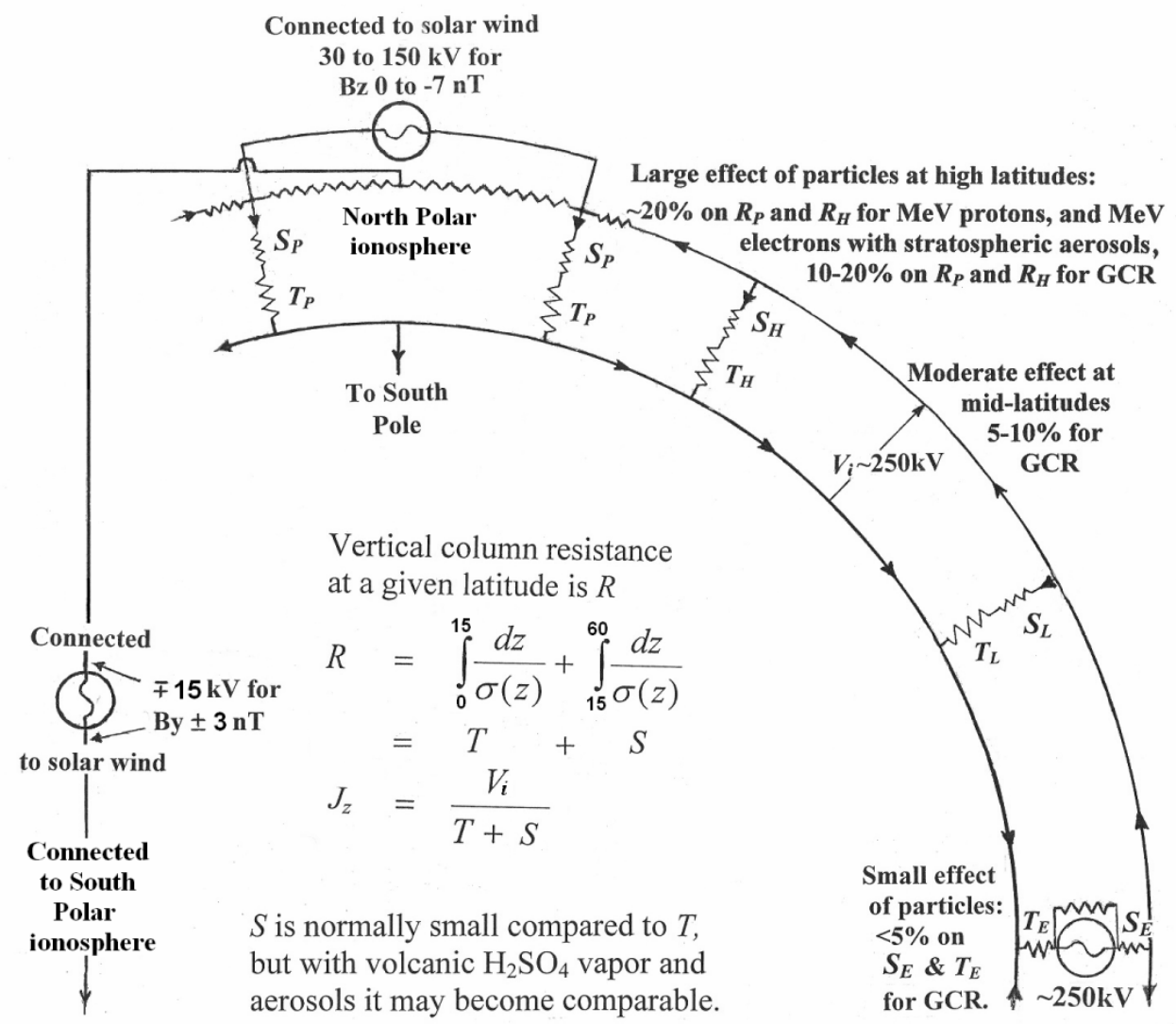

$S$  is normally small compared to  $T$ , but with volcanic  $\text{H}_2\text{SO}_4$  vapor and aerosols it may become comparable.

Tinsley and Zhou, JGR, 2006, Fig. 2

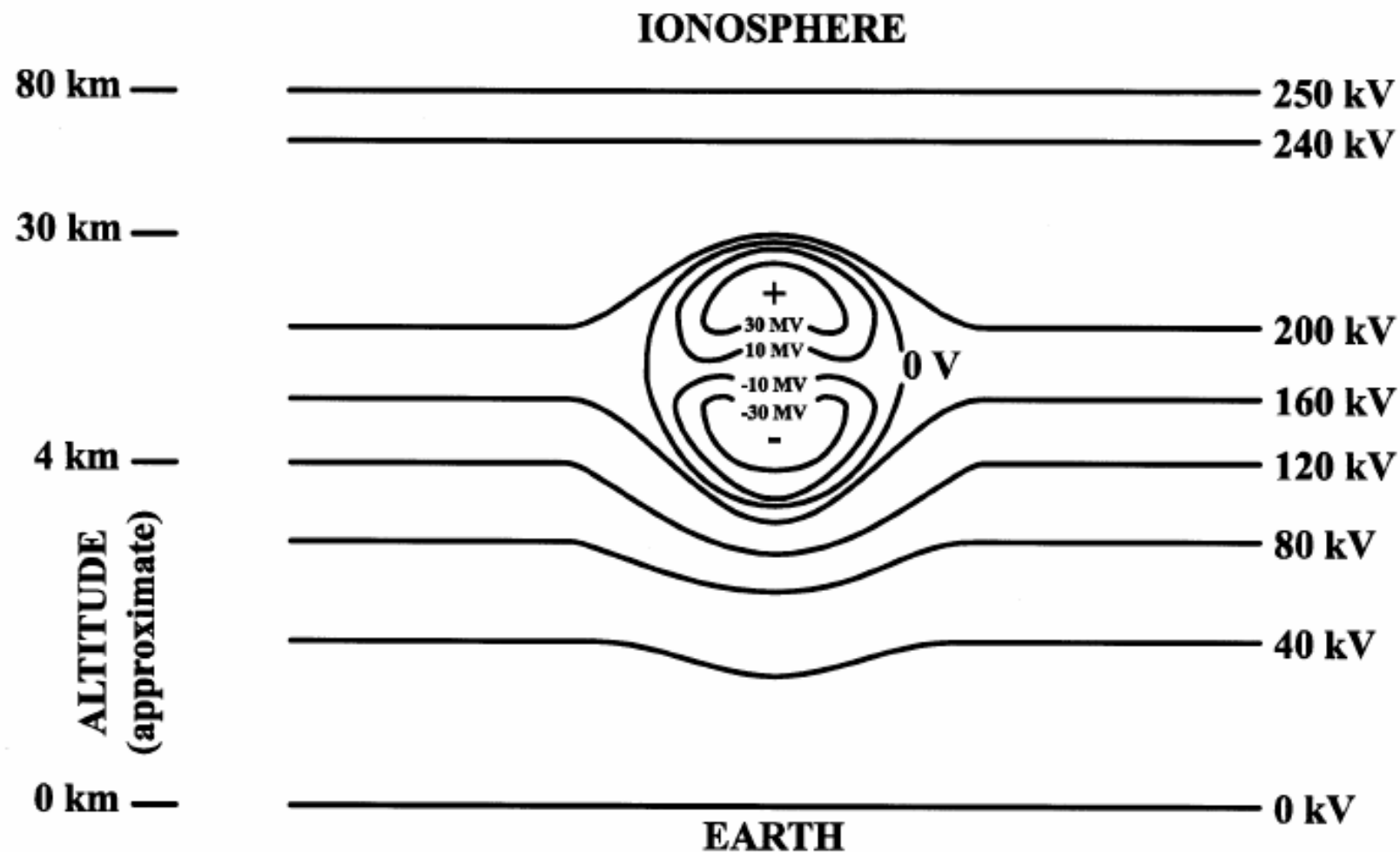

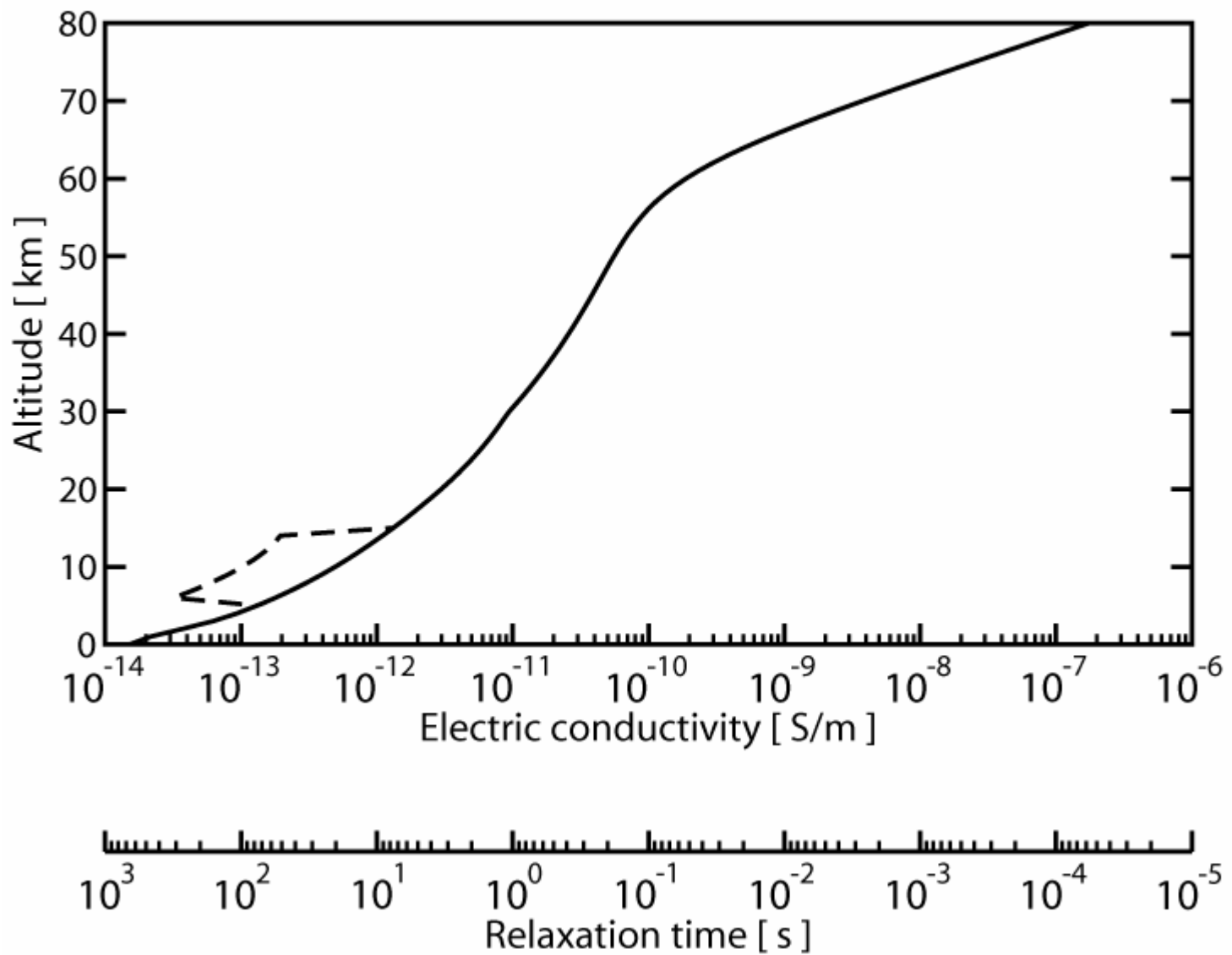

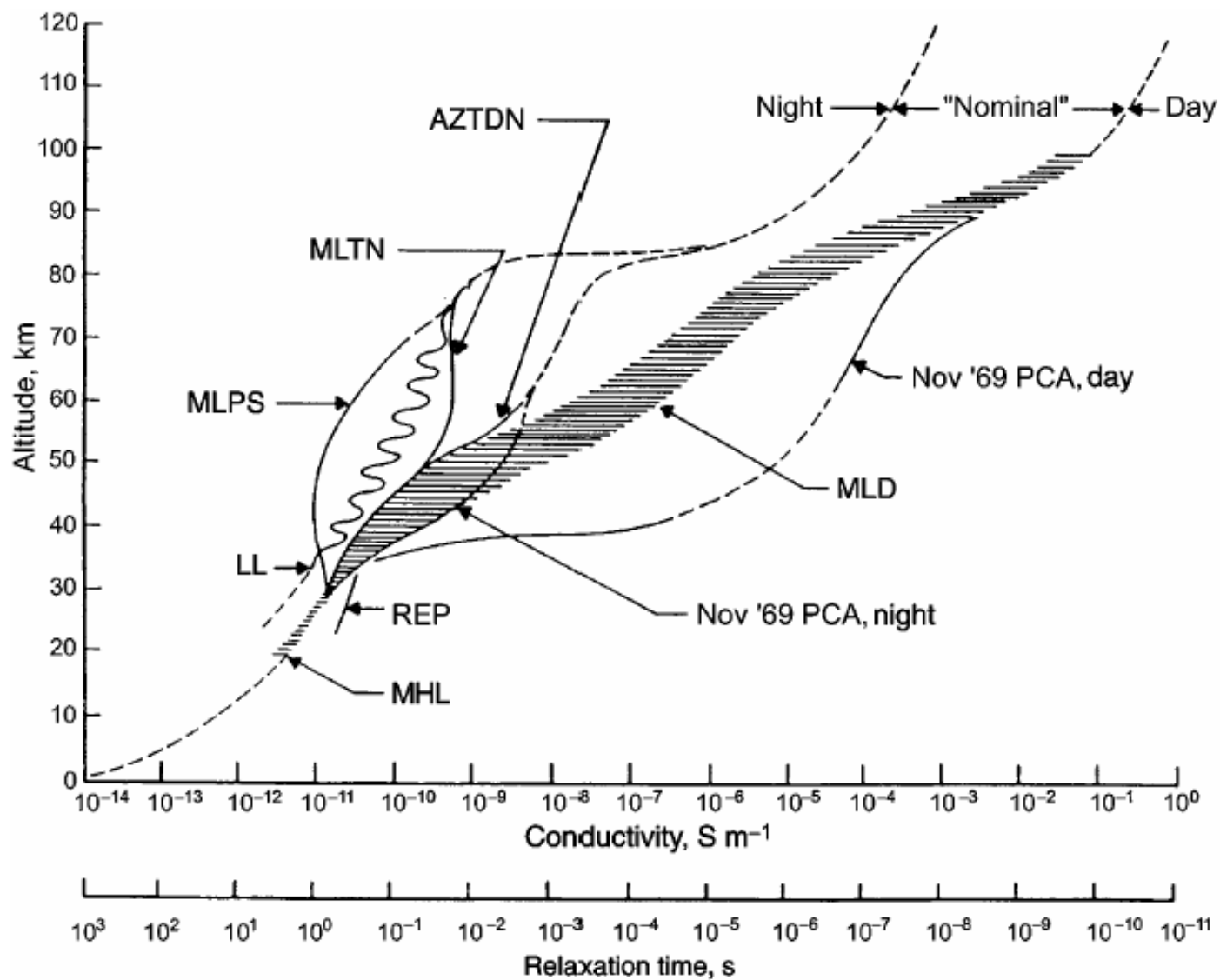

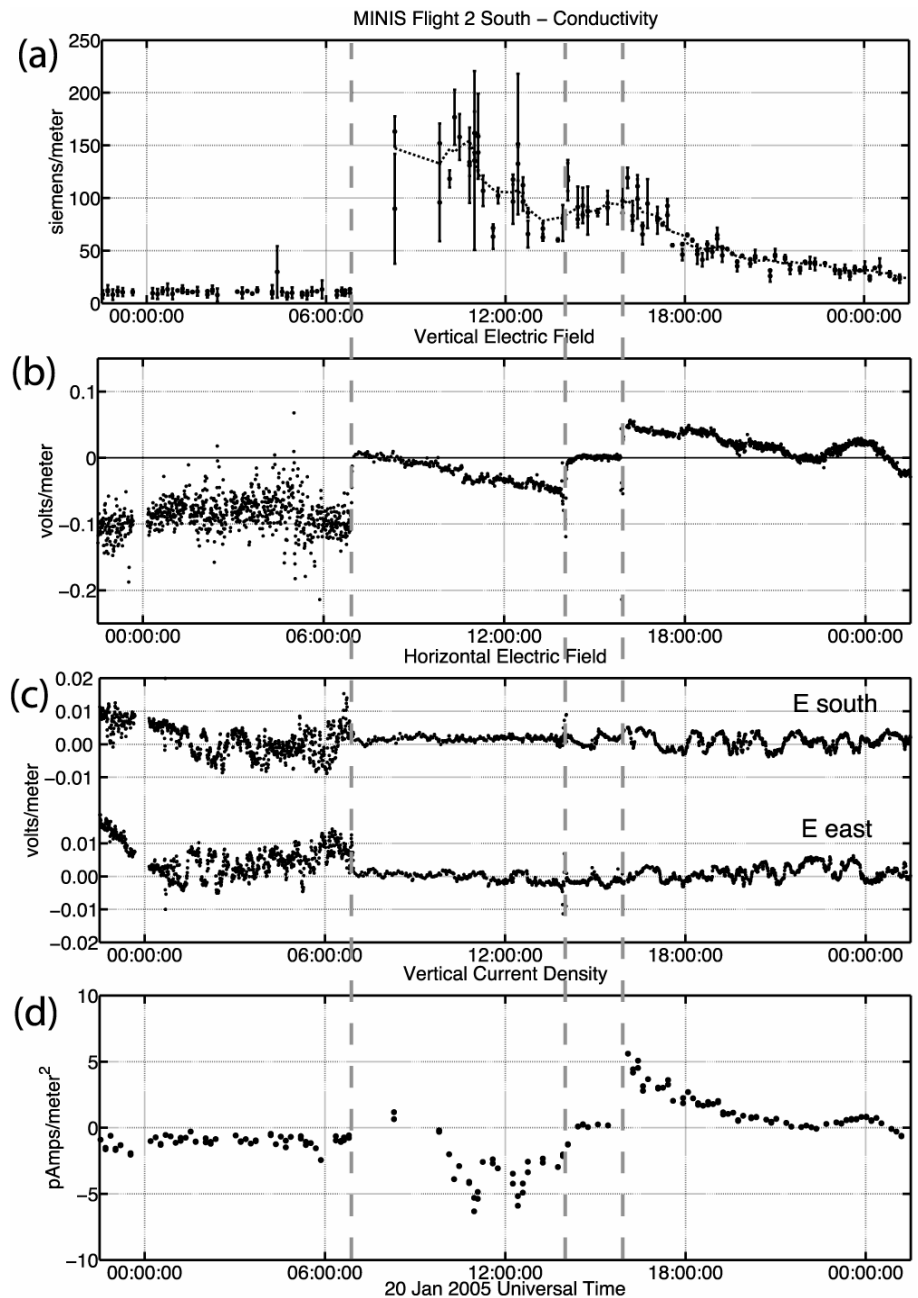

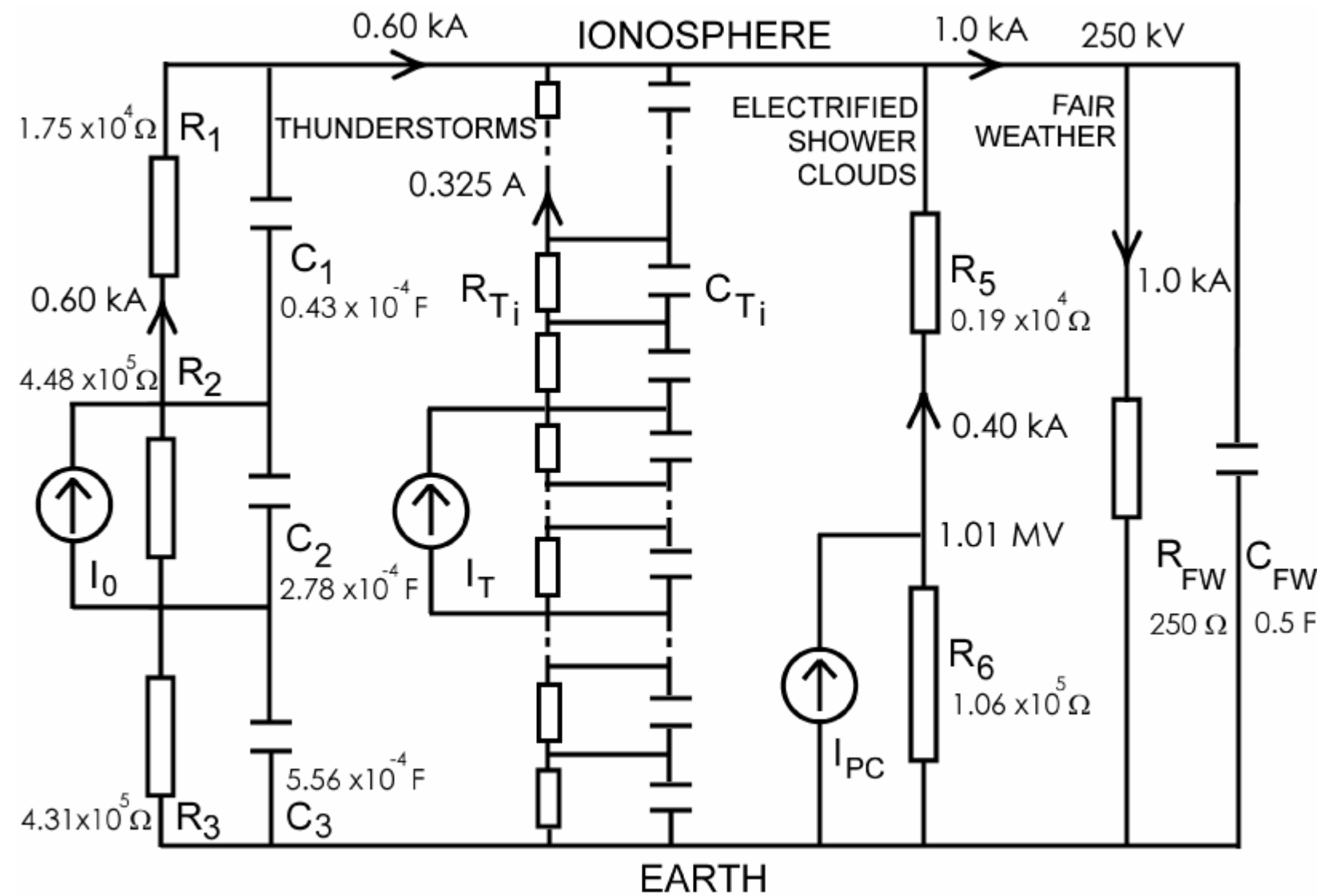

Rycroft et al., JASTP, 2007, Fig. 12

## FAIR WEATHER REGION

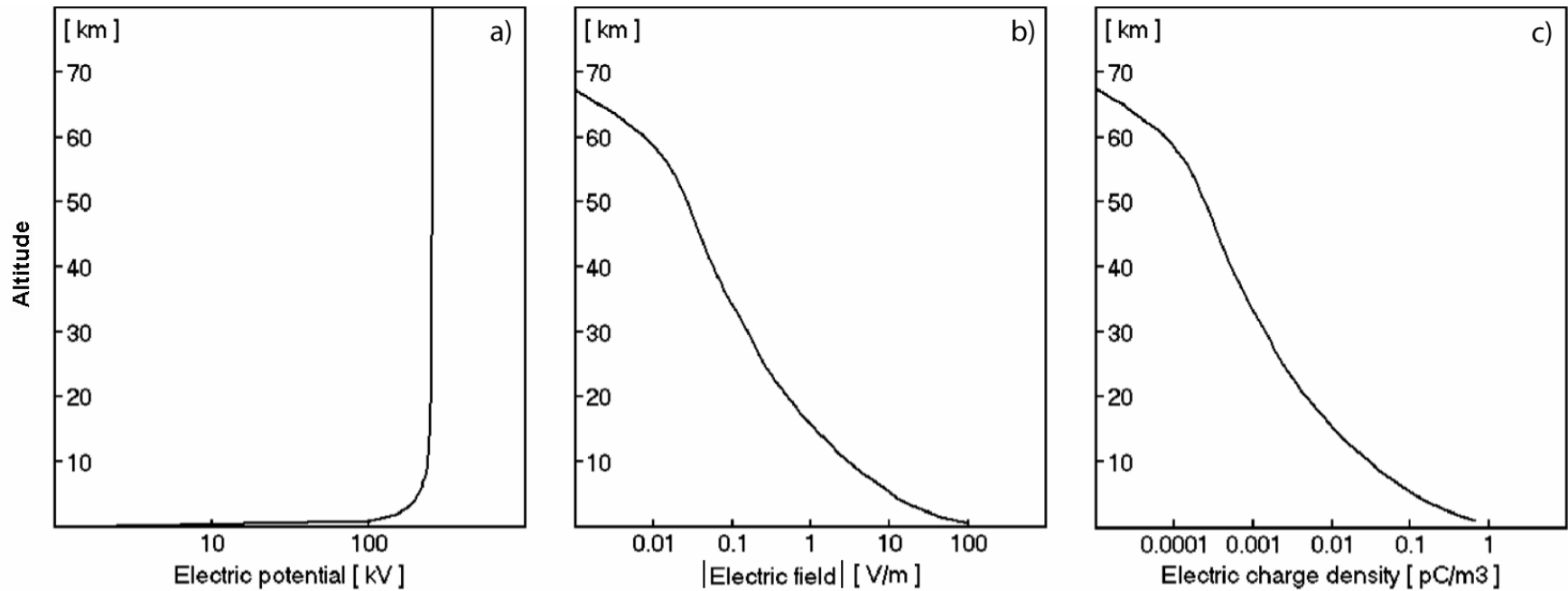

## SPATIAL AND TEMPORAL VARIATIONS OF GLOBAL CIRCUIT

Ohm's law  $\underline{J} = \sigma \underline{E}$  applies in both the

**CHARGING** part of circuit ("battery"), where  $\underline{J} \cdot \underline{E}$  is negative, and  
**DISCHARGING** part of circuit, where  $\underline{J} \cdot \underline{E}$  is positive.

Considering simplest situations, four different types of variability may occur:

- i) if  $\sigma$  is constant,  $J$  and  $E$  are linearly related,
- ii) if  $J$  is constant and  $\sigma$  is increased,  $E$  decreases,
- iii) if  $E$  is constant and  $\sigma$  is increased,  $J$  increases in proportion to  $\sigma$ , and
- iv)  $J$ ,  $\sigma$  and  $E$  may vary independently.

**SPATIAL VARIABILITY** – varying geographic location.

Land or ocean, weather type, pollution, volcanic eruption, .....

Geomagnetic latitude – greater ionisation at higher latitudes.

## TEMPORAL VARIABILITY – AC GLOBAL CIRCUIT

<b>microseconds</b>	<b>– lightning discharge processes</b>
<b>milliseconds</b>	<b>– VLF/ELF radio phenomena</b>
<b>~ 0.1 s</b>	<b>– Schumann resonances of Earth-ionosphere cavity</b>
<b>minute to 1 hour</b>	<b>– evolution of thunderstorm cells, and thunderstorms</b>
<b>day</b>	<b>– changes with local time, or Universal Time, Carnegie curve</b>
<b>27 days</b>	<b>– solar rotation</b>
<b>0.25 year</b>	<b>– season</b>
<b>0.5 year</b>	<b>– semi-annual</b>
<b>1 year</b>	<b>– annual</b>
<b>1.68, few years</b>	<b>– El Nino/Southern oscillation, Quasi Biennial Oscillation?</b>
<b>11 years</b>	<b>– solar cycle.</b>

## SPATIAL VARIABILITY – varying geographic location

**As solar activity increases from solar minimum to solar maximum, solar ultraviolet flux increases, decreasing height of lower ionosphere slightly, and heliospheric magnetic field become more disturbed, causing more scattering of galactic cosmic rays away from Earth's magnetosphere, appreciably reducing electrical conductivity of stratosphere, especially at high latitudes (Ney, Nature, 183, 451-452, 1959), increasing  $R_1$ , resistance above thunderstorms, in generator part of the circuit, and raising ionospheric potential (for thunderstorm current generator not varying with solar cycle).**

## CARNEGIE CURVE AND THUNDERSTORMS

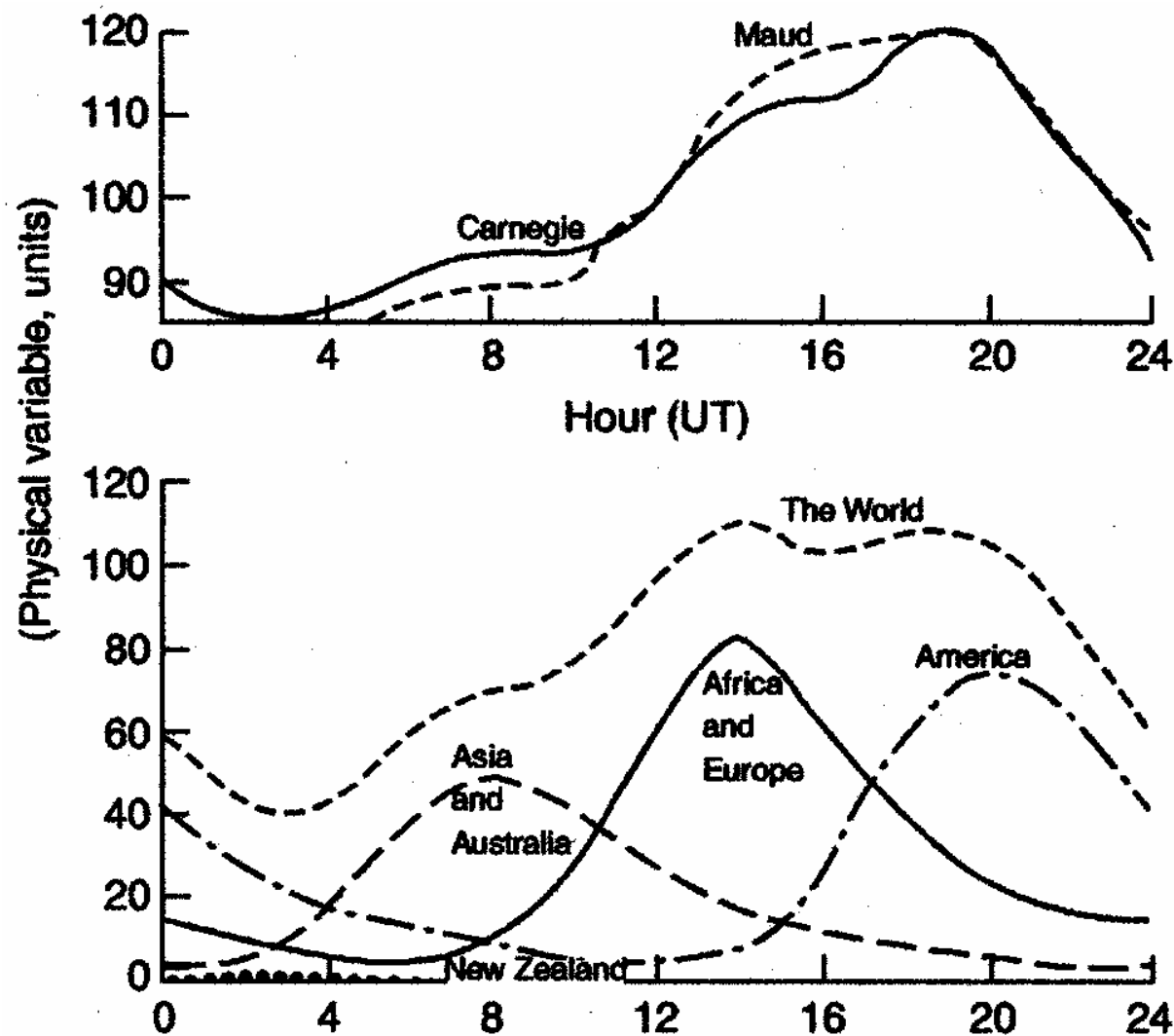

# SPRITES AND ELVES – SCHEMATIC DIAGRAM

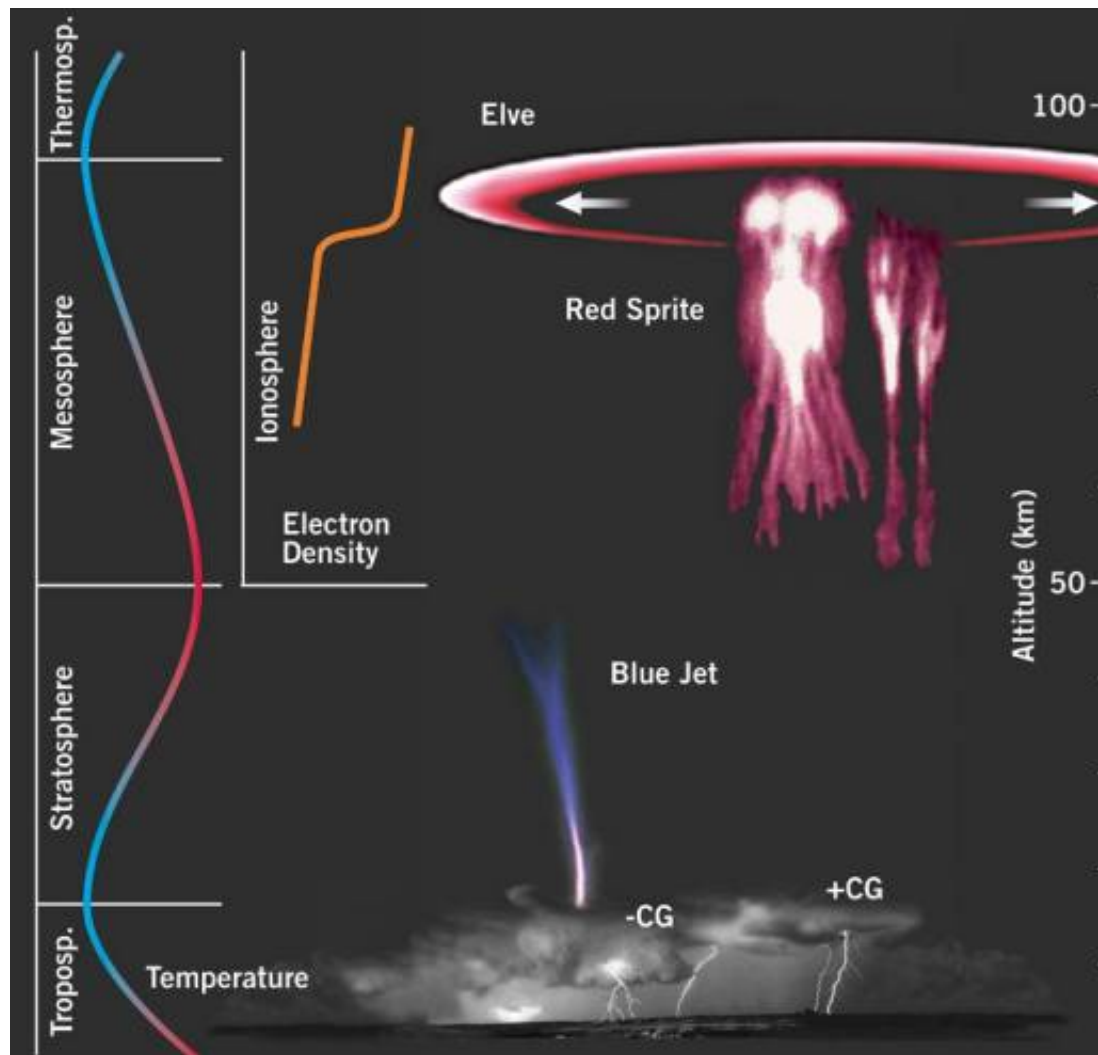



**Sprites over France, 29 July 2005, 01.40:50 UT, Eurosprite2005 campaign**



Sprites over France, 11 August 2005, 22.44:15 UT, Eurosprite2005 campaign

## DIAGRAMMATIC LIGHTNING DISCHARGES (IN RED)

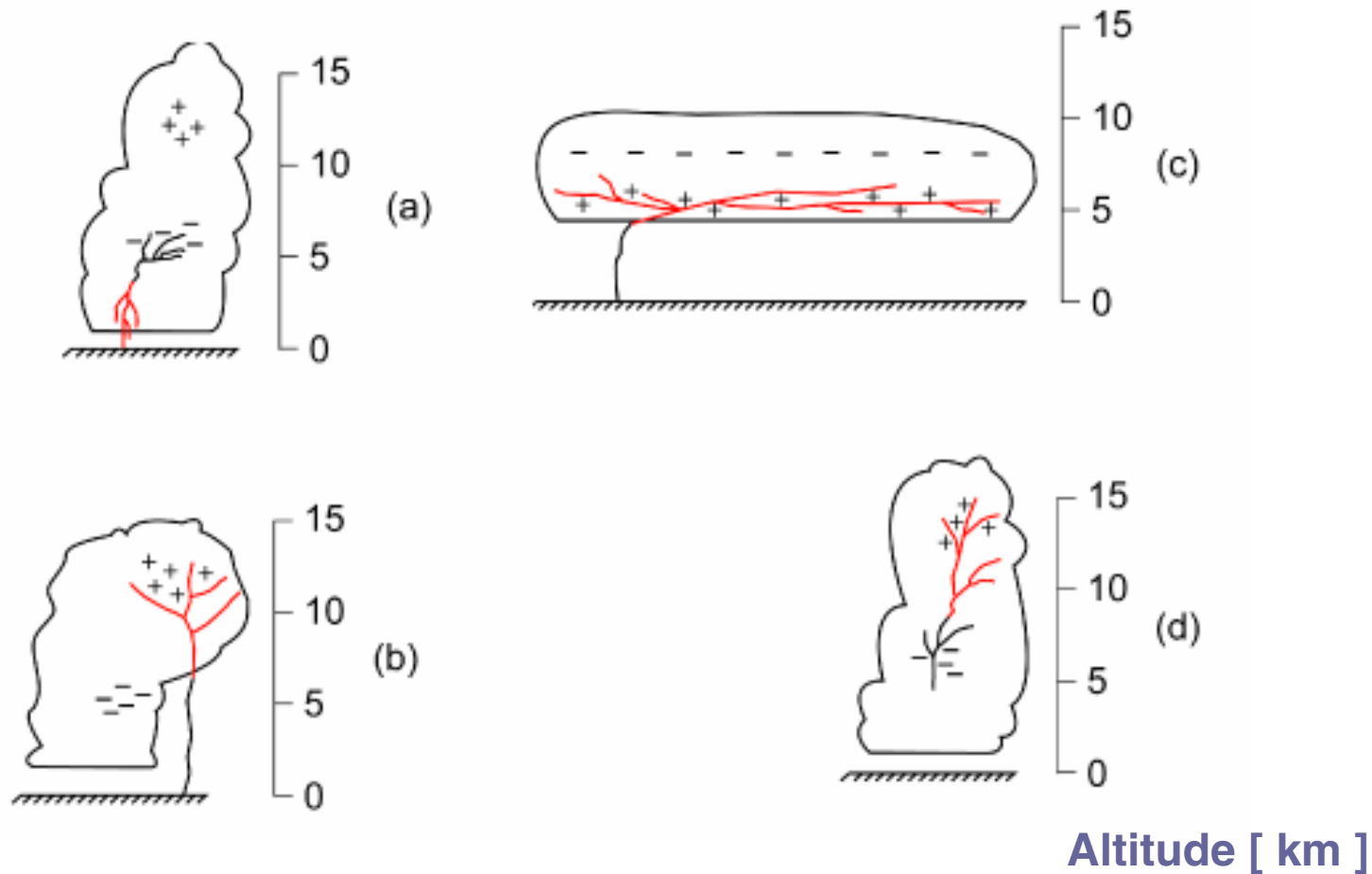

# SPRITES, ELVES AND INTENSE LIGHTNING – SOME KEY POINTS

**INTENSE LIGHTNING**, over mid West of USA, near end of intense Mesoscale Convective System, ahead of cold front, at night.

**+CG discharge**, taking ~ +100 C from height of 5 km to ground; continuing current is important.

Charge moment formed by charge and its image in ground, large, ~100 C km, is destroyed.

Equivalent to current of 100 kA, flowing horizontally for ~15 km or more, then vertically to ground.

For discharge lasting ~ 1ms, current moment is ~ 1000 kA km.

**ELVES**, due to strong electromagnetic pulse (EMP) from large +CG discharge

(Huang et al., JGR, 104, 16943-16964, 1999) current ~ 50-200 kA.

Heats atmosphere at ~90 km altitude, ~0.3 ms after discharge.

Heated electrons excite nitrogen molecules which radiate N<sub>2</sub> first positive band (red).

Appears as ring expanding horizontally at ~> speed of light (300 km/ms).

**SPRITES** occur ~few ms after +CG discharge.

Intensity several hundred kiloRayleighs or more; first positive band of nitrogen (red),

and also N<sub>2</sub><sup>+</sup> first negative band and second positive band (blue).

Start at 70-75 km, develop as downward positive streamers with bright tips, reaching 50 km in 2.5 ms; bright “dots” of light also appear.

Simultaneously, upper portion brightens considerably, and spreads upward (negative streamers).

Become diffuse glow where  $\sigma$  too large to support streamer propagation.

~10 ms after discharge, transient luminous events (TLEs) below 65 km have faded.

Core between 65 and 77 km remains.

Sometimes, sprites develop from bottom of “halo” of light at 73 km altitude

(Cummer et al., GRL, 2006: Submillisecond imaging of sprite development and structure).

## SPRITE IMAGES AT HIGH RESOLUTION

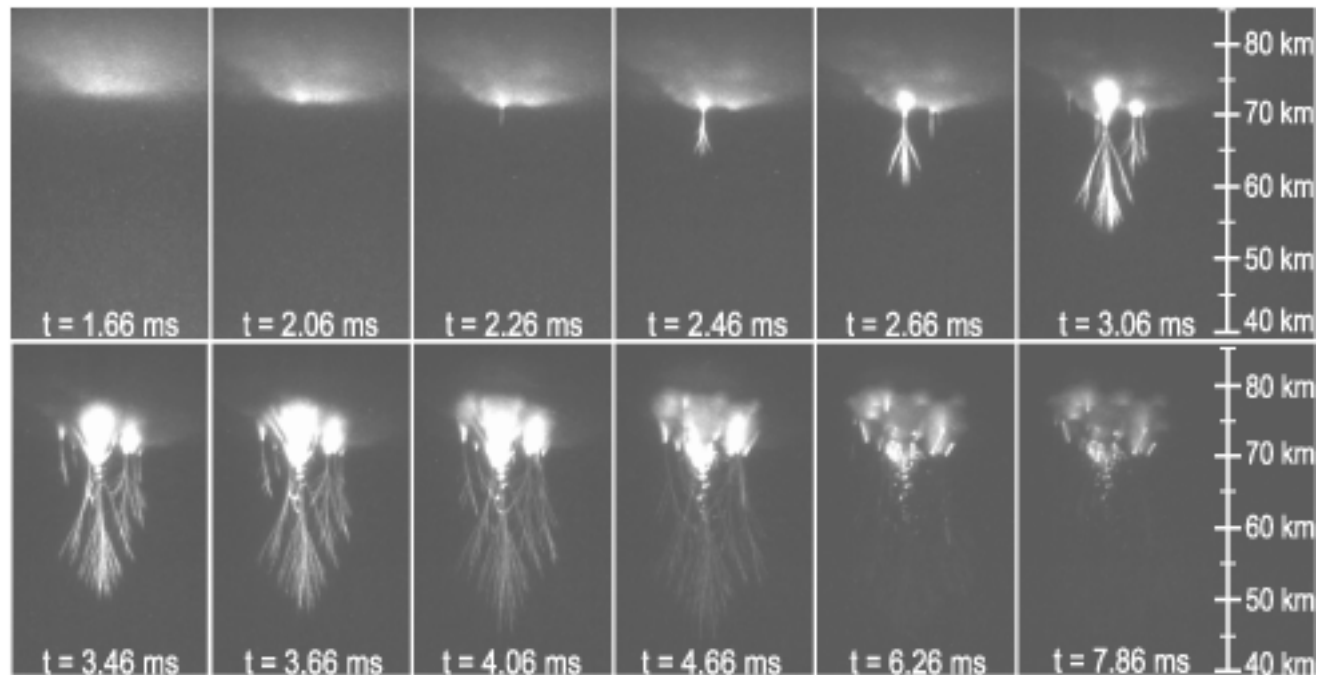
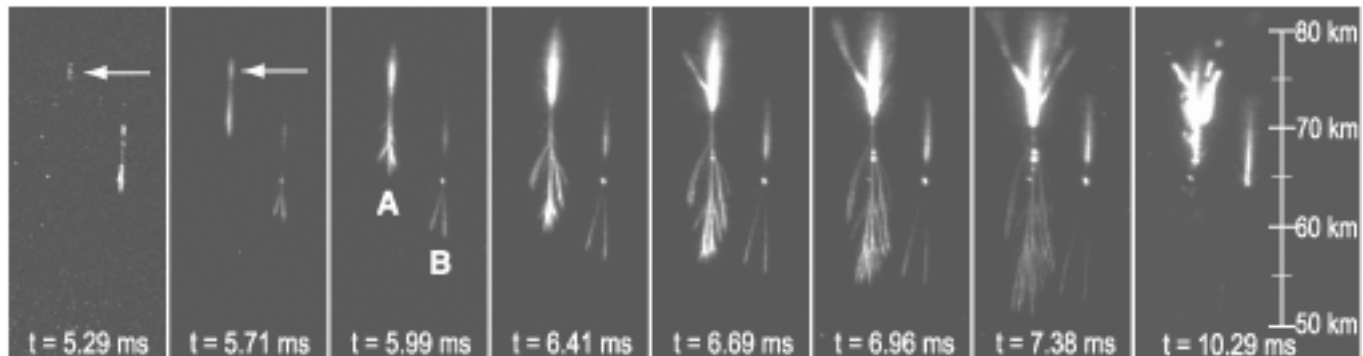

## SPRITES – MORE KEY POINTS

**ELF radiation (up to 1 kHz) by sprites: Cummer et al., GRL, 25, 1281-1284, 1998.**

**Model as column of enhanced  $\sigma$ , currents  $\sim 5$  kA flowing for  $\sim 2$  ms over 25 km height interval.**

**With its image in ionosphere, current moment amplitude  $\sim 250$  kA km.**

**Equivalent charge moment change  $\sim 500$  C km;  $\sim$ half that of causative +CG discharge.**

**In agreement with observations of**

**Hu et al., GRL, 29, GLO014593, 2002, and Cummer and Lyons, JGR, 110, A010812, 2005.**

**$\mathbf{J} \cdot \mathbf{E}$  positive for +CG discharge, or for sprite.**

**Both represent dissipation of the global atmospheric electric circuit.**

**For sprite extracting 10 C from  $2 \times 10^5$  C stored in spherical capacitor, one sprite removes  $0.5 \times 10^{-4}$  of charge stored in global circuit, reducing fair weather electric field by same proportion.**

**About 3 sprites per minute, globally.**

**Could a change of fair weather electric field be detected experimentally, using a “superposed epoch” analysis method?**

**Streamer-like structures in sprites have diameters of 10-300 m, and generally persist for 2-3 ms:**

**Marshall and Inan, Radio Science, RS003353, 2006.**

**See discussion by Williams, Plasma Sources Sci. Technol., 15, S91-108, 2006.**

# SPRITES – THEORY OF GENERATION PROCESS

**Electric field above thunderstorm associated with redistribution of charge after +CG discharge is believed to be basic energy source for sprites.**

**Streamers formed when this field exceeds threshold for conventional breakdown via propagation of positive streamers; this decreases with increasing altitude as neutral gas density decreases.**

**Computer codes (either electromagnetic or electrostatic) solve Maxwell's equations self-consistently through atmosphere, with model  $\sigma$  profile, for response of middle/upper atmosphere to lightning discharge currents and thunderstorm fields.**

**i) Conventional discharge when threshold field is exceeded; see**

**Rowland et al., JASTP, 60, 831-844, 1998**

**Cho and Rycroft, JASTP, 60, 871-888, 1998**

**63, 559-580, 2001**

**Pasko, in Fullekrug et al. book, Chapter 12, 2006**

**Ebert et al., Plasma Sources Sci. Technol., 15, S118-129, 2006.**

**ii) Runaway (relativistic) electron discharge**

**For lightning initiation, see Gurevich and Zybin, Physics Today, 58, 37-43, May 2005**

**For sprite initiation, see Rousell-Dupré et al., JASTP, 60, 917-940, 1998.**

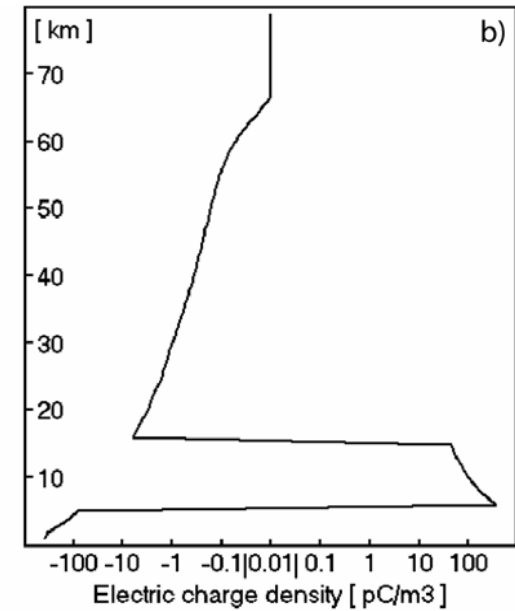
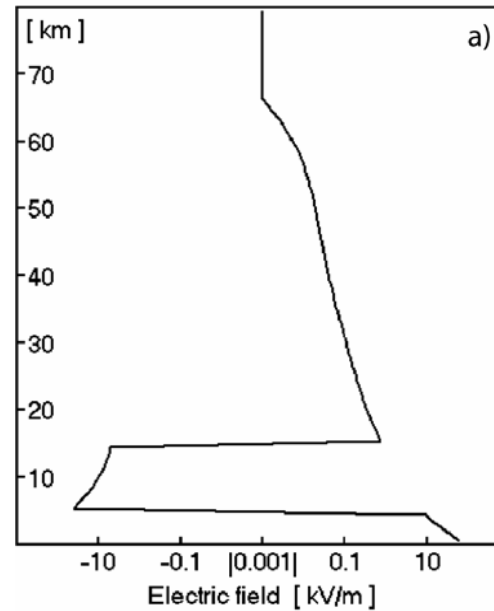
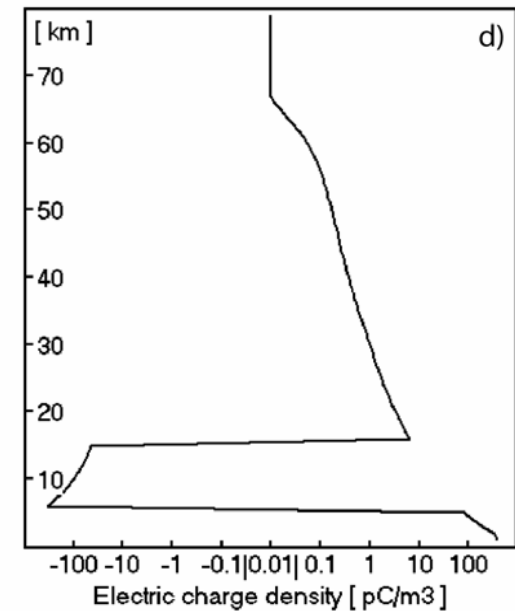
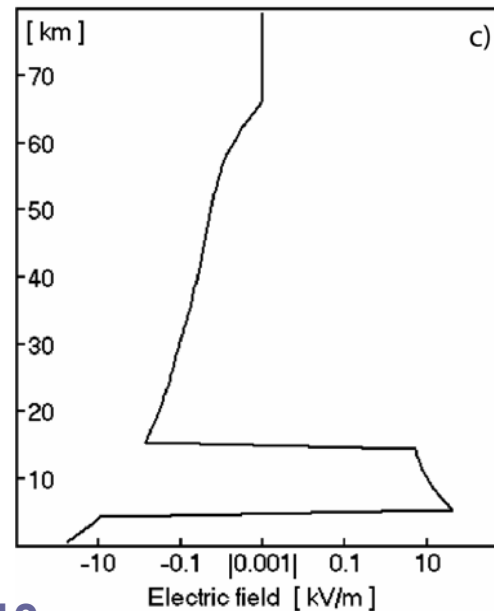
**-CG PRODUCING STORM****+CG PRODUCING STORM**

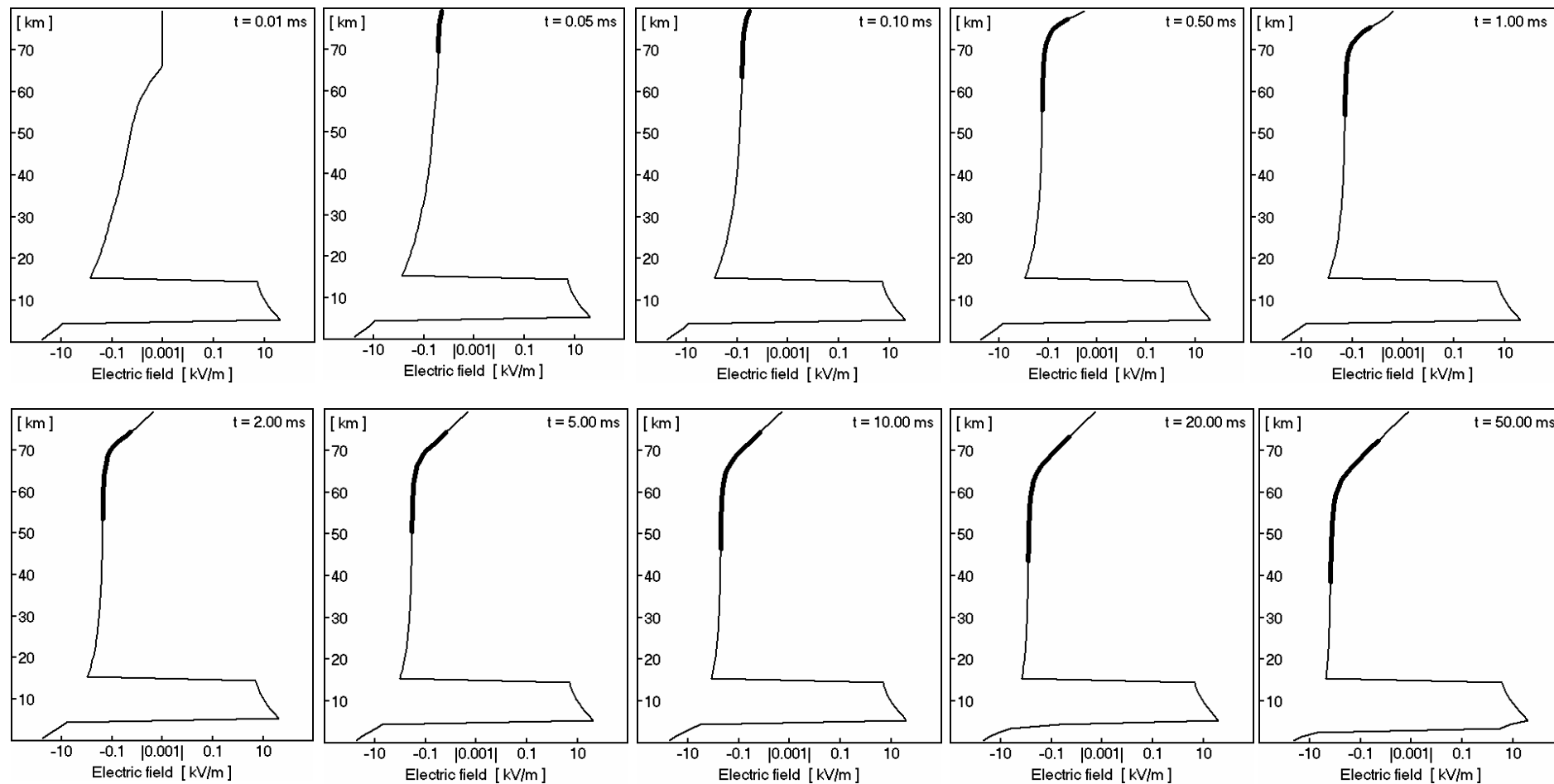

**BOLD LINES SHOW WHERE THRESHOLD FIELD IS EXCEEDED**

# IONOSPHERIC POTENTIAL AFTER LIGHTNING DISCHARGE

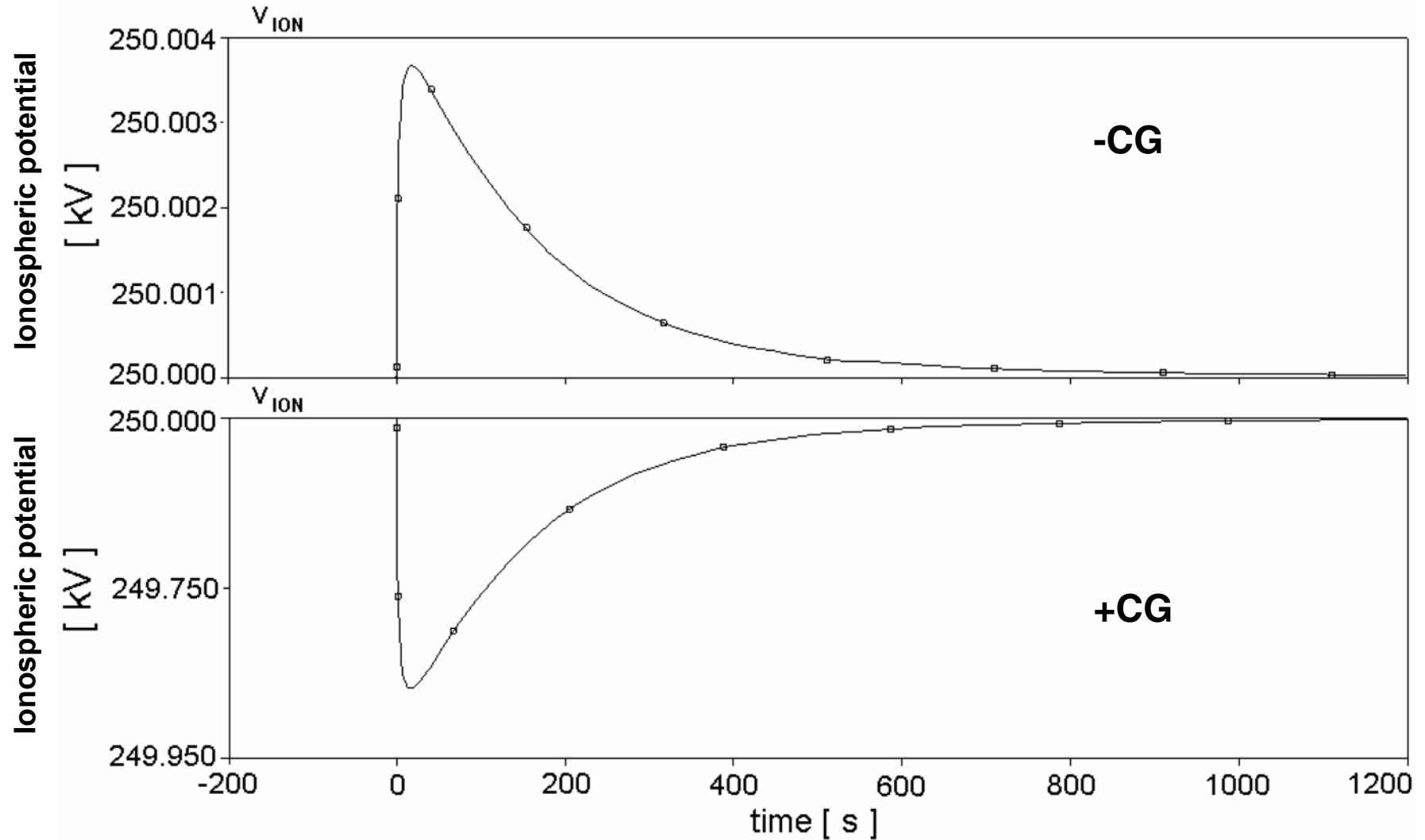

CHANGE AFTER +CG DISCHARGE ( $\square$ )  
AND AFTER SPRITE ( $\diamond$ )

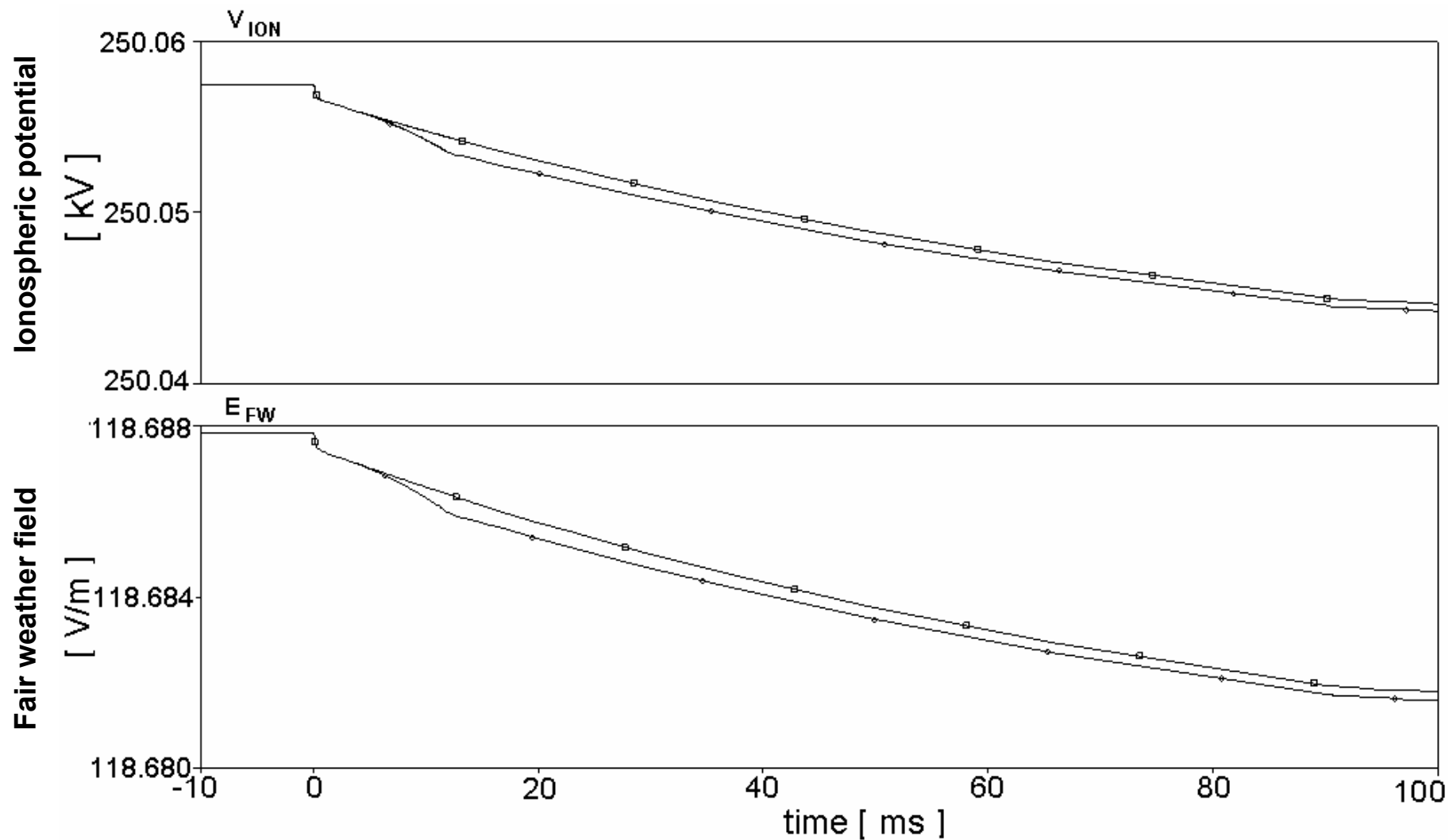

# CHANGES DURING SPRITE DEVELOPMENT

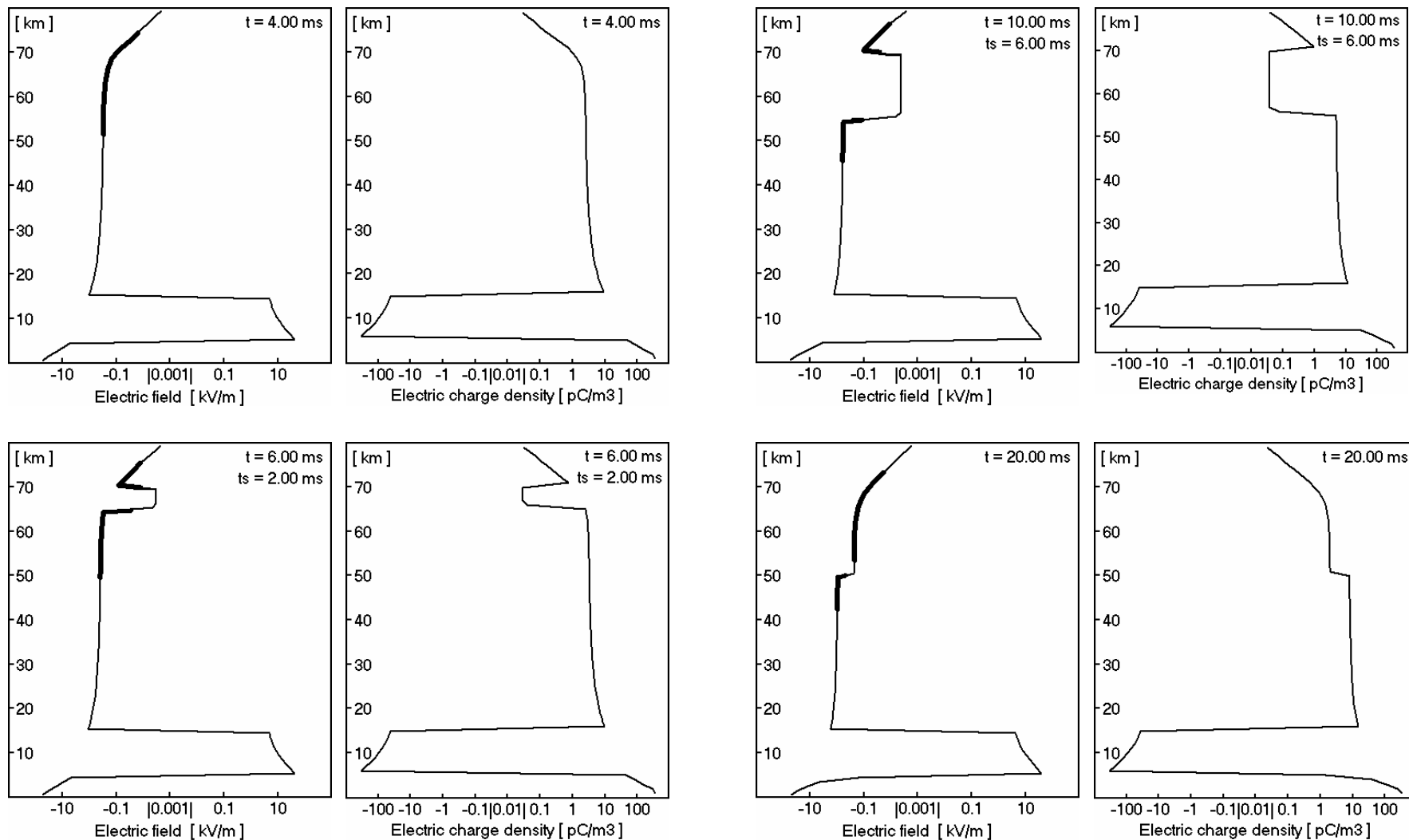

**BOLD LINES SHOW WHERE THRESHOLD FIELD IS EXCEEDED**